

Installation Manual

BKH 5.0 flat
50-82

green

©2024

BRUNNER[®]
made in germany.

CONTENTS

1	Basic informations.....	3
2	Safety precautions.....	4
3	Specified symbols.....	5
4	Delivery contents BKH 50-82 flat.....	6
	4.1 Catalytic converter (optional).....	9
	4.2 Air connection box (optional).....	10
	4.3 cast iron heat exchanger rings (optional).....	10
5	Safety distances BKH flat.....	11
6	Setting up.....	13
	6.1 Remove the transport locks.....	13
	6.2 Set up the fireplace.....	14
	6.3 Variant with external combustion air connection.....	15
	6.4 Variant with EAS or EOS.....	30
7	Fitting: catalytic converter.....	42
8	Fitting: deflection - combustion chamber.....	46
9	Variants heat exchanger.....	54
	9.1 Connection with catalytic converter.....	54
	9.2 Connection without catalytic converter.....	55
	9.3 Cast iron dome.....	60
	9.4 Heat exchanger rings.....	62
	9.5 Heat exchanger MAS.....	72
10	Frame variants.....	78
	10.1 Mounting frame or door frame.....	78
	10.2 Mounting frame or door frame (BKH - side with tilting door).....	81
11	Conversions, settings.....	87
	11.1 Modification - lifting door: "non self closing".....	87
	11.2 Retrofitting EAS/EOS.....	90
12	Disposal.....	91
13	Technical data.....	92

1 BASIC INFORMATIONS



All instructions delivered with products must be observed. We do not accept any warranty claim or liability for damage resulting from failure to observe these installation instructions!
Improper installation can cause injury and material damage!

The floor space of the room must have a suitable structure and sufficient dimensions to ensure proper functioning of the fireplace.

Please note that other installation and assembly instructions are included in other packaging units!

Dimensioning of downstream heat accumulator must be according to valid stove-setting rules.

During installation of the fireplace, all dimensions and minimal clearances of the fireplace casing must be held as specified by the manufacturer.

All binding national or EU standards and local regulations for the installation of fireplaces must be observed.

All valid stove fitting rules and regulations of local construction law must be observed and followed.

Please follow the relevant regulations of your country.

When these instructions are followed and all works are done properly, this will ensure a safe, energy-saving and environmentally friendly operation of the stove. Pictures shown are not to be considered as complete representations of any kind.

Subject to technical and assortment changes.

Please notify your supplier of any damage which might have occurred during transport.

Please keep these instructions.

Please also take note of the online product documentation provided by:



[General instructions of the Brunner products installation for the stove construction.](https://www.brunner.de/produktdownloads/kachelofen-kamine/allgemeine-hinweise-fuer-den-aufbau_de.pdf)

(https://www.brunner.de/produktdownloads/kachelofen-kamine/allgemeine-hinweise-fuer-den-aufbau_de.pdf) laden können.



2 SAFETY PRECAUTIONS

Fireplaces may be set up only in rooms or areas with no risk of danger due to their location, structure or intended use.

Working on the stove Installation, commissioning, servicing and maintenance works on the product may be carried out only by an authorized stove-fitter. Safety and efficiency of the system depend on this!

Working with electronics Switch off the emergency switch or circuit breaker, and secure them against switching on again.



Fireplaces with external air supply are not independent from room air supply and must be considered and designed as roomsealed fireplaces. In connection with a ventilation or extraction system, we recommend the use of a negative pressure safety device (Art.No.: 11600.1).

Installation must be carried out by an authorized stove-fitter, because safety and efficiency of the system depend mostly on proper installation of the product. All valid stove fitting rules and regulations of building law must be observed and followed. Make sure to instruct the owner or user about the functions and controls of the system and possibly installed safety devices.

Fireplaces must be built to ensure safe operation and fire safety in order to eliminate possible risks and unacceptable loads. They have to be ready for use over an adequate period of time.

Make sure to instruct the owner or user about the functions and controls of the system and possibly installed safety devices.

Remember to use only genuine replacement parts.

3 SPECIFIED SYMBOLS

In this documentation, a distinction is made between:

Operating personnel as the **User of the system**, i.e. the end user, which has received instructions from the Contractor and does not necessarily have additional qualifications.

Operating personnel as the **Contractor**, i.e. the qualified professionals, which are entitled to perform the indicated specialist works.

In this document, the following symbols are used:



DANGER

A danger of high risk persists, which leads to severe injury or death, if this endangering situation is not avoided.

WARNING

A danger of medium risk persists, which can lead to severe injury or death, if this endangering situation is not avoided.

CAUTION

A danger of low risk persists, which can lead to minor or moderate injury, if this endangering situation is not avoided.



ATTENTION

There is a certain risk, which can lead to a malfunction or damage of the related system and all devices connected with it, if the indicated notifications are not followed.



NOTE

Additional helpful information

4 DELIVERY CONTENTS BKH 50-82 FLAT

BKH 50-82 flat with lifting door

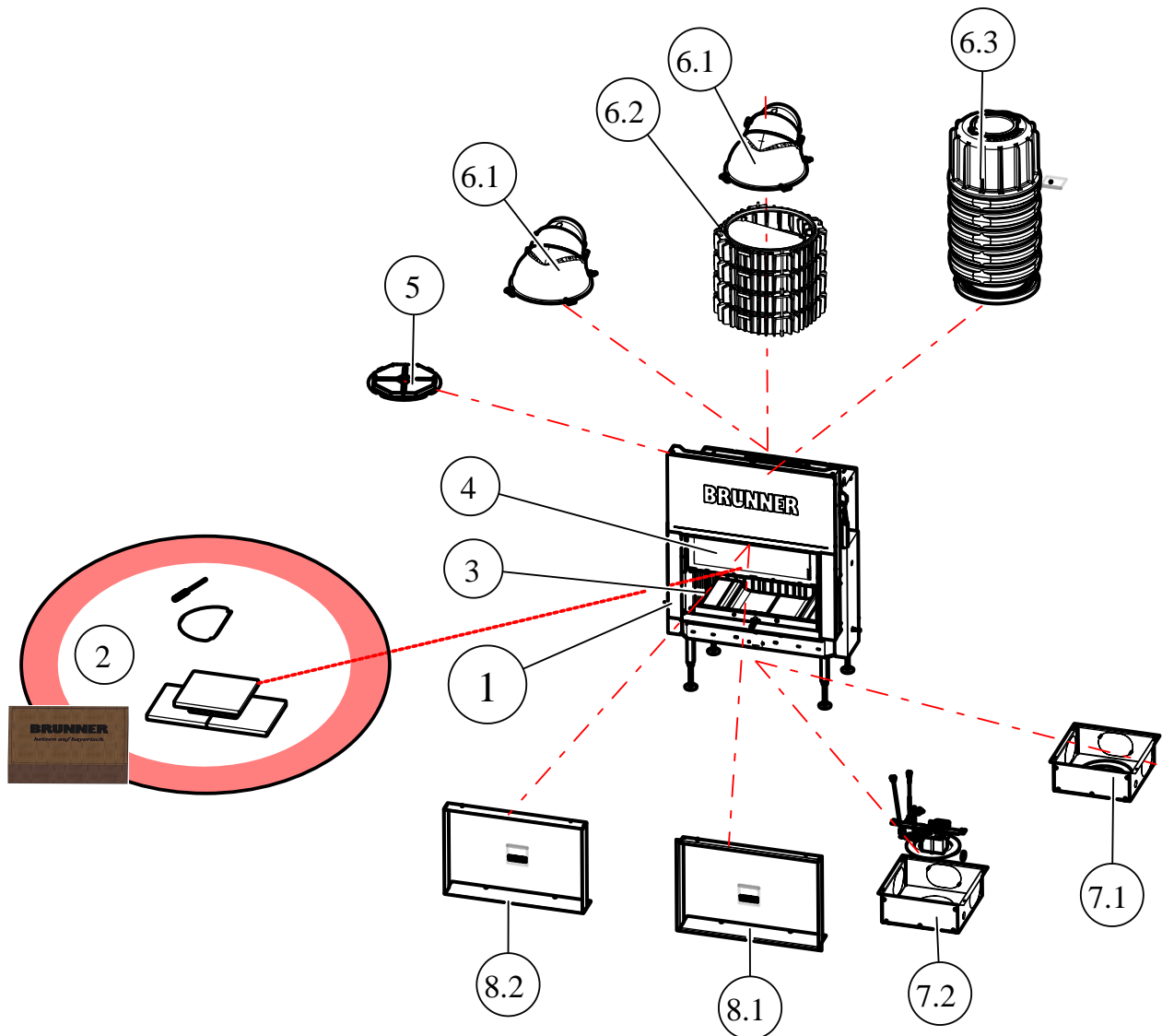

Pos.	Designation	Art. No.
1	BKH variants:	
	BKH 5.0 Flach 50-82 ST with manual operation	
	Ceramic glass (GK) chamotte inner lining (FR)	HK007002-01
	Glaskeramik beschichtet (GKB) chamotte inner lining (FR)	HK007002-05
	BKH 5.0 Flach 50-82 ST for EAS/EOS	
	Ceramic glass (GK) chamotte inner lining (FR)	HK007002-02
	Glass ceramic coated (GKB) chamotte inner lining (FR)	HK007002-06
	BKH 5.0 Flach 50-82 ST with manual operation	
	Ceramic glass (GK) Cast iron inner lining (FR/Guss)	HK007002-03
	Glass ceramic coated (GKB) Cast iron inner lining (FR/Guss)	HK007002-07
	BKH 5.0 Flach 50-82 ST for EAS/EOS	
	Ceramic glass (GK) Cast iron inner lining (FR/Guss)	HK007002-04
	Glass ceramic coated (GKB) Cast iron inner lining (FR/Guss)	HK007002-08
	2	The non-installed parts (e.g. deflection plates, control levers, etc.) and any accessories ordered (e.g. catalytic converter, packaging with EOS, etc.), including the instructions box, are packed in the combustion chamber
3	Combustion chamber lining:	
	- made of Chamotte	
	- made of Cast iron	
4	Ceramic glass (GK)	
5	Catalyst module BKH 5.0	HK000210
Smoke hood variants		
6.1	Rotating cast iron dome with adjustable connecting piece \varnothing 180 mm	D004186
	Rotating cast iron dome with connecting piece d=200 mm	10087
6.2	with heat exchanger rings (4)	R015006-04
6.3	Connection variant MAS SET440	SET211444
Additional options		
7.1	Supply air connection box \varnothing 125 mm	HK000135
	Supply air connection box \varnothing 150 mm	HK000136

Pos.	Designation	Art. No.
7.2	Supply air connection box ø 125 mm with EOS / EAS	HK000080
8.1	Door frame, black	HK007152-01
8.2	Mounting frame, black	HK007150-01

4.1 CATALYTIC CONVERTER (OPTIONAL)



The catalytic converters are coated with a catalytically active layer. This coating can consist of mixed metal oxides or also of precious metals. In order not to limit the effect of this catalytically active layer, the catalysts may only be handled with gloves, preferably with disposable gloves.



In order not to limit the effect of this catalytically active layer, the catalysts may only be handled with gloves, preferably with disposable gloves.



ATTENTION

The catalysts are fragile and must only be handled with care. Avoid bumping and do not drop the catalytic converter. This could destroy the catalytic converter!

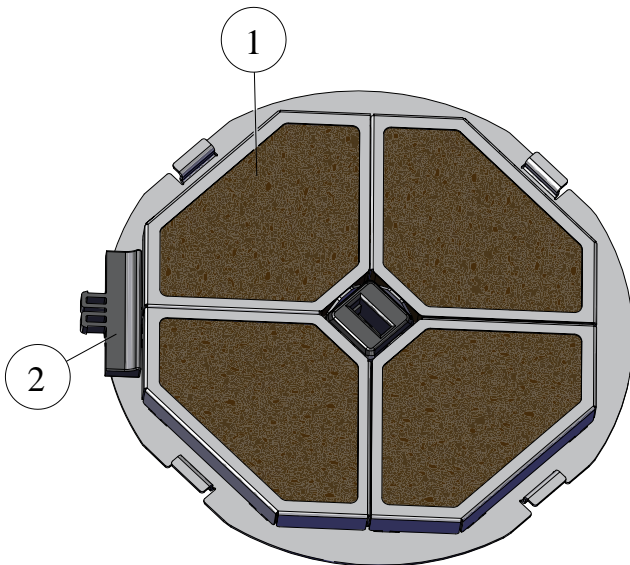

1	catalytic converter
2	assembly tool



Note

This catalytic converter is suitable for all BKH units (with lifting door, with side opening door, tunnel, with cast dome, with heat exchanger cast rings and MAS).

This catalytic converter can also be retrofitted.

4.2 AIR CONNECTION BOX (OPTIONAL)

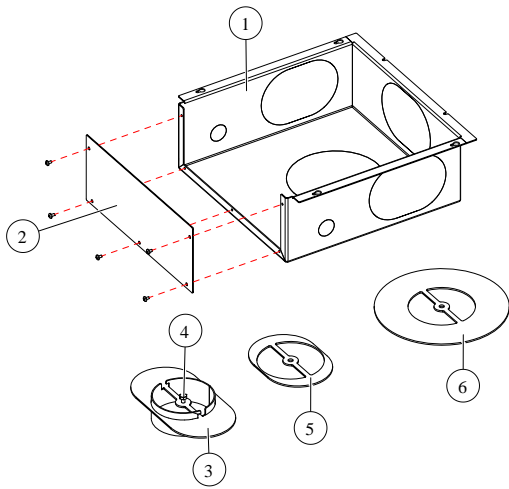

Pos.	Description of use
1	Air connection box - allows the connection of an external combustion line
2	Cover for air connection box
3	Air connection is welded, connection point for combustion air line
4	Screw for fixing the respective clamping plate
5*	Clamping plate for fixing the external combustion air line on the side
6*	Floor clamping plate for fixing the external combustion air line to the floor

*both clamp plates are supplied, but only the appropriate one is used.

4.3 CAST IRON HEAT EXCHANGER RINGS (OPTIONAL)

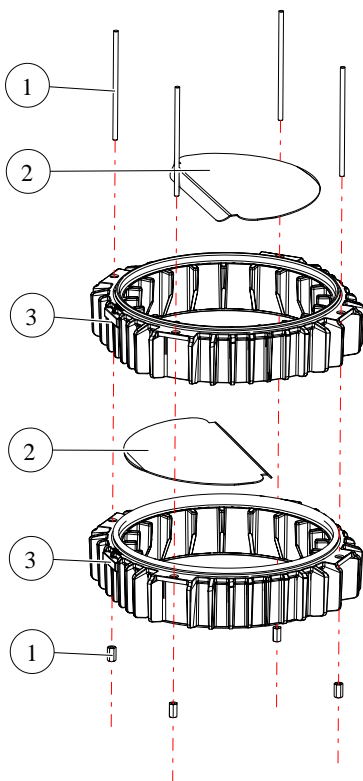

1	separate package (4x threaded rod, 4x hexagon nut)
2	deflection heat exchanger (2x)
3	with heat exchanger rings (2x)

5 SAFETY DISTANCES BKH FLAT





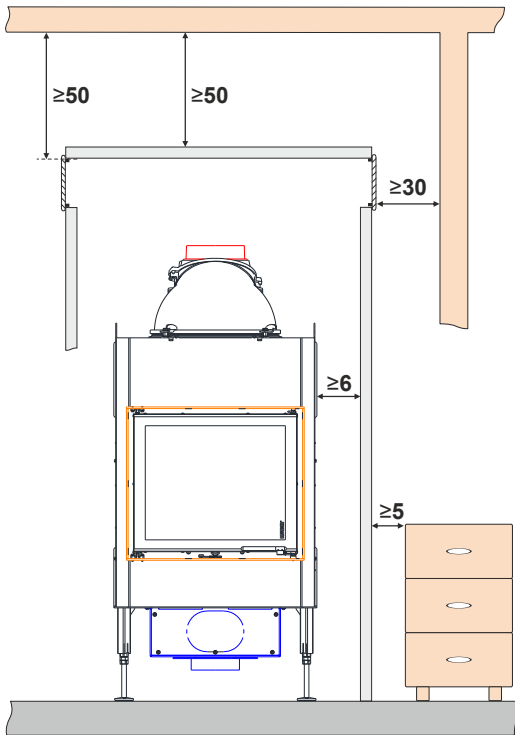

Half-height version

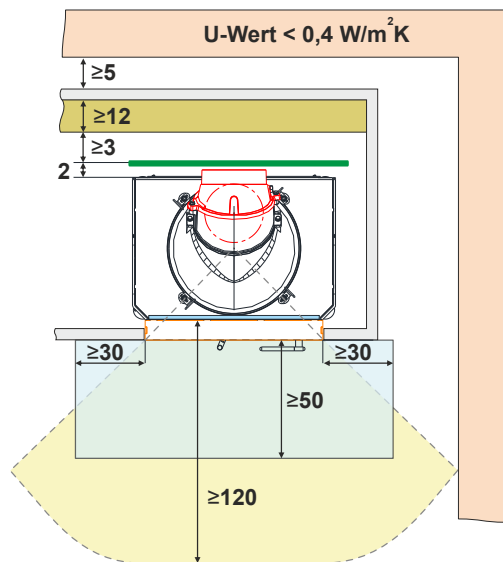
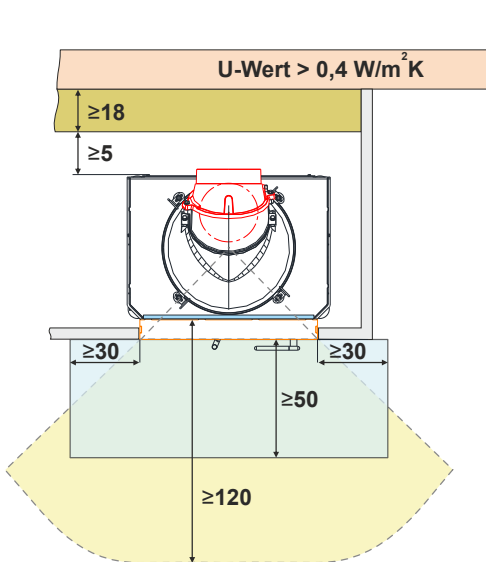
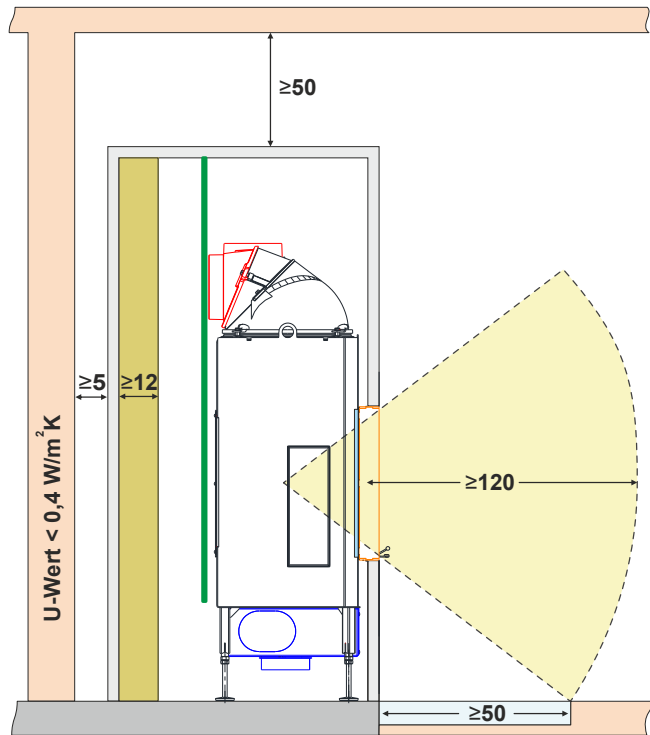
without heat protection panel



with heat protection panel



- | | | | |
|---|---|---|---|
|  | floor/wall/ceiling non-combustible |  | convection opening |
|  | wall/ceiling/floor/attachments combustible/to be protected |  | radiation range |
|  | substitute insulation material calcium silicate (Promasil 950-KS) |  | non-combustible flooring /floor protection pane |
|  | heat protection panel (accessories) | | |

All figures in cm

When designing the exhaust system and exhaust pipe, national standards and fire protection regulations must be observed





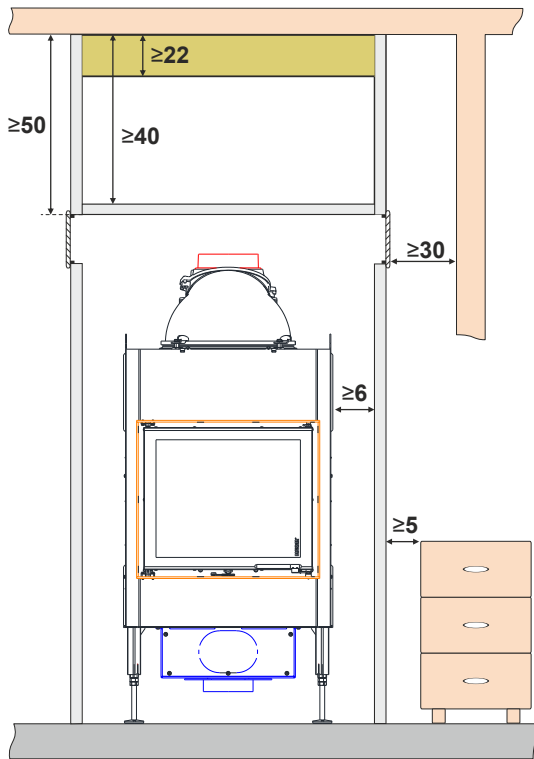

Floor-to-ceiling version

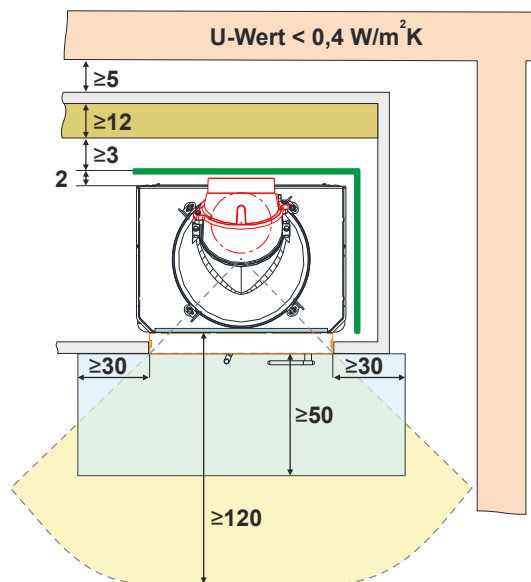
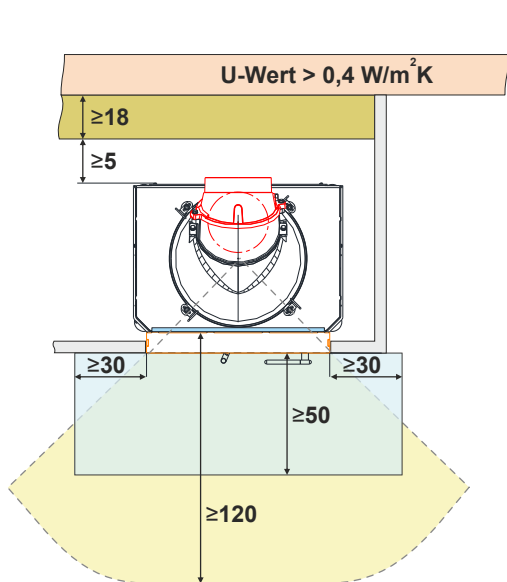
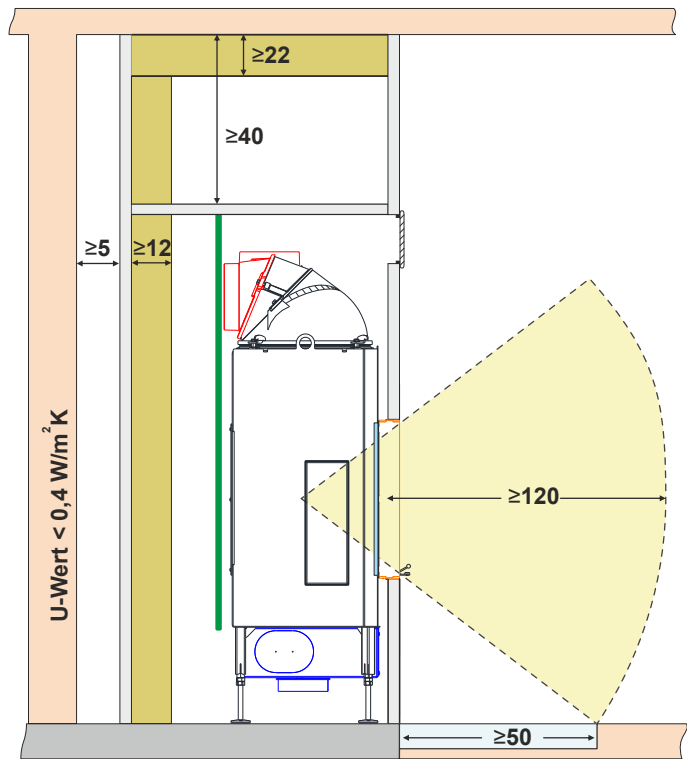
without heat protection panel



with heat protection panel

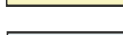

- | | | | |
|---|---|---|---|
|  | floor/wall/ceiling non-combustible |  | fireplace cladding |
|  | wall/ceiling/floor/attachments combustible/to be protected |  | convection opening |
|  | substitute insulation material calcium silicate (Promasil 950-KS) |  | radiation range |
|  | heat protection panel (accessories) |  | non-combustible flooring /floor protection pane |

All figures in cm

When designing the exhaust system and exhaust pipe, national standards and fire protection regulations must be observed

6 SETTING UP

**DANGER**

Possible personal injury and/or property damage caused by improper installation

Assembly and installation of BKH requires extensive specialist knowledge.

- Assembly and installation works must be performed by authorized professionals.

**Danger**

Risk of injury caused by heavy loads

Carrying of heavy loads can lead to injuries.

- The equipment should be carried by at least two people.
- Use appropriate carrying aids.
- Keep the transport weight in mind.

As long as the device is on the wooden pallet, it can be transported with a hand truck or forklift as usual.

6.1 REMOVE THE TRANSPORT LOCKS

Version with side-opening door 



NO TRANSPORT LOCK !

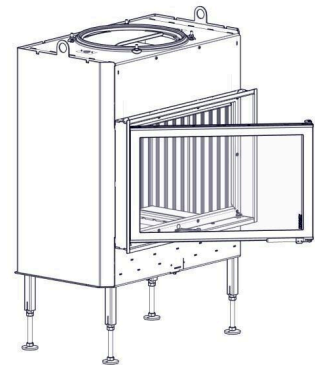

Version with lifting door 



Remove the 3 transport locks !

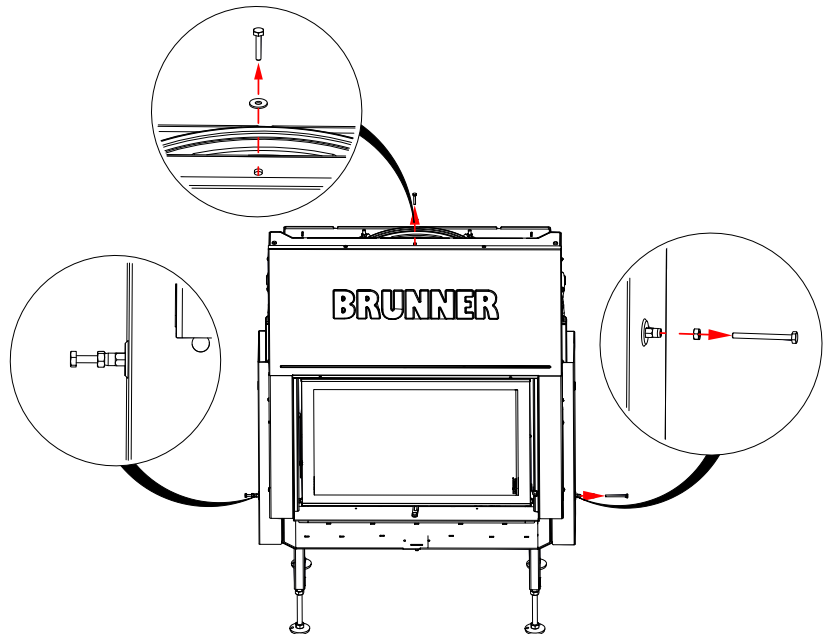

6.2 SET UP THE FIREPLACE

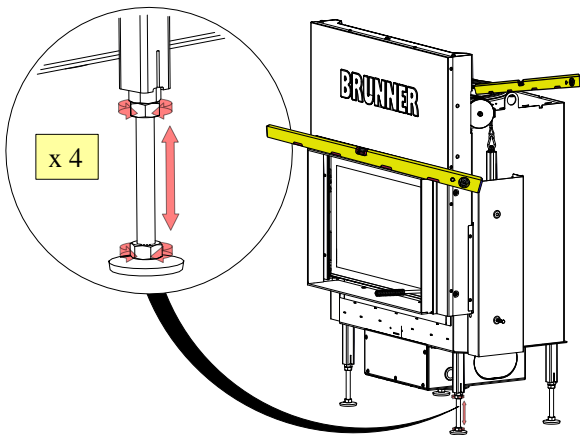

Im. 1: Summarised information

Version without outside air connection

BHK with lifting door

Workflow :

1

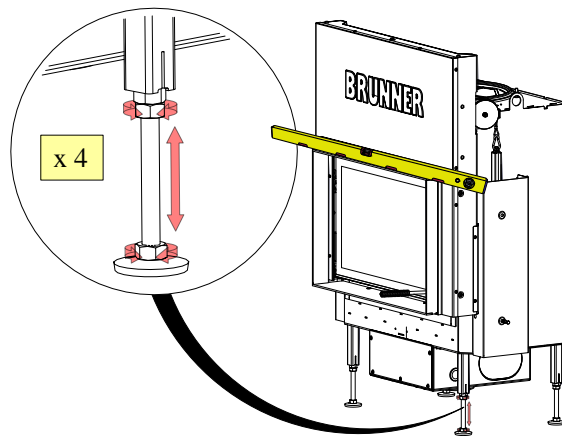

2

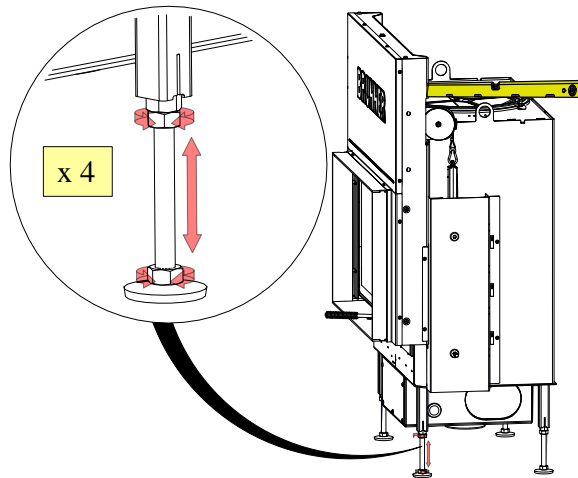

6.3 VARIANT WITH EXTERNAL COMBUSTION AIR CONNECTION

Preparatory work

Workflow:

1

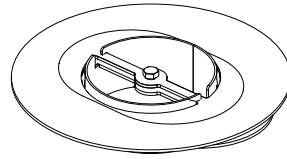
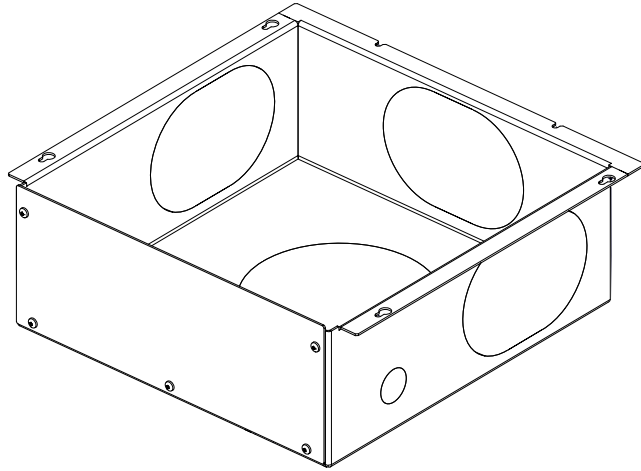

2

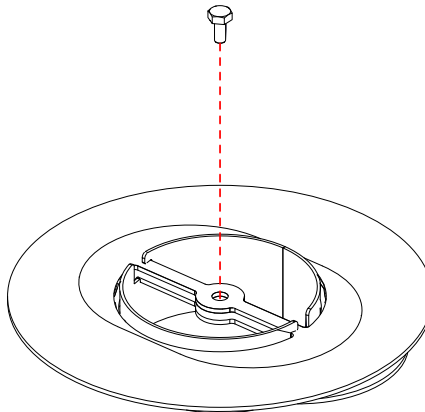

3

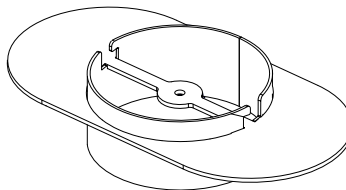
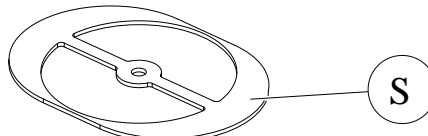
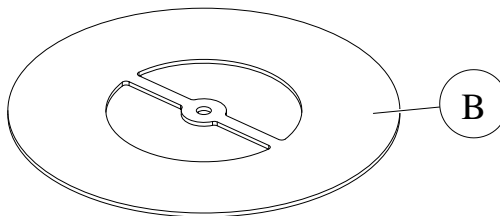

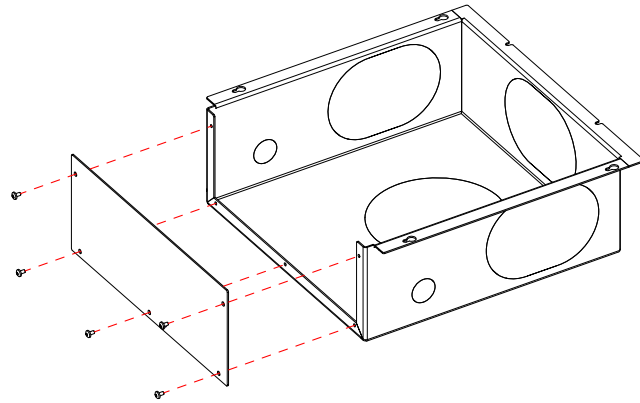
4

Im. 2: Recommended for easier handling

Depending on the planning, the air connection is possible - using aluxflex on 3 lateral parts (S) and also from the bottom (B).

Once you have made a decision, break out the appropriate part and make the connections for the air supply.

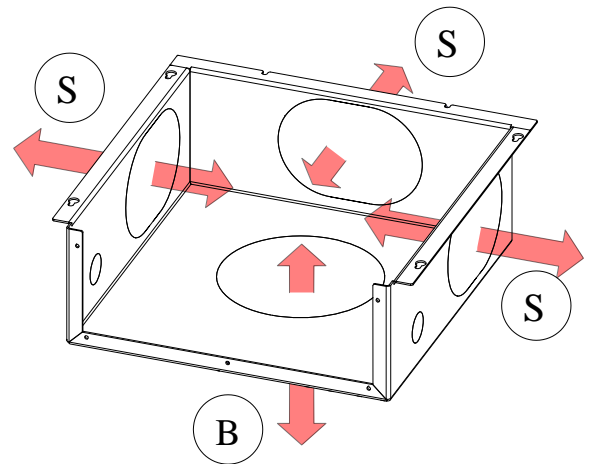

6.3.1 BOTTOM CONNECTION (B)

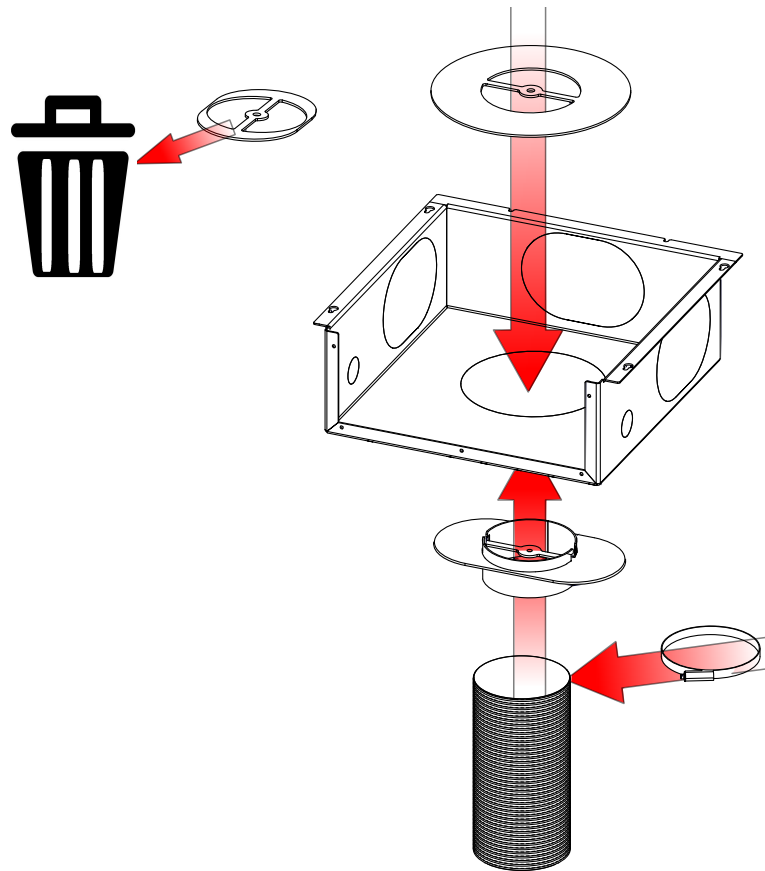

Im. 3: Summarised information

Workflow:

5

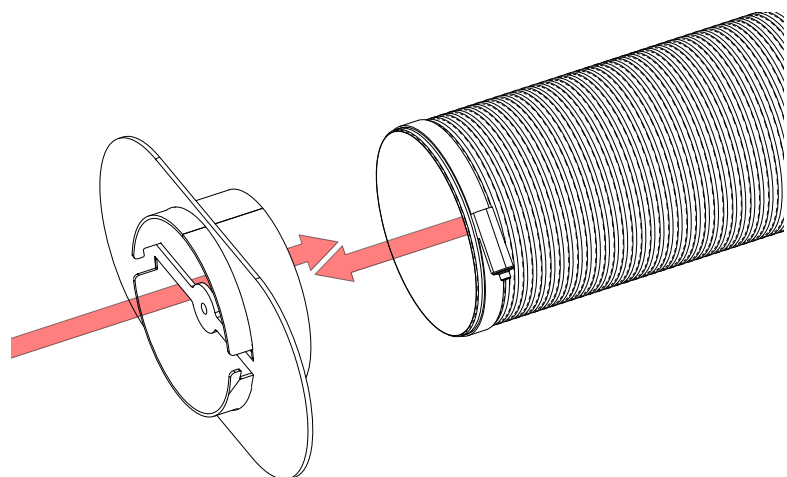

6

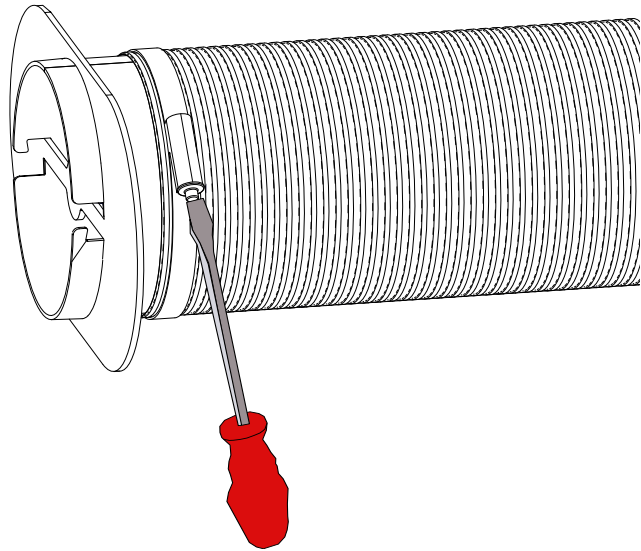

7

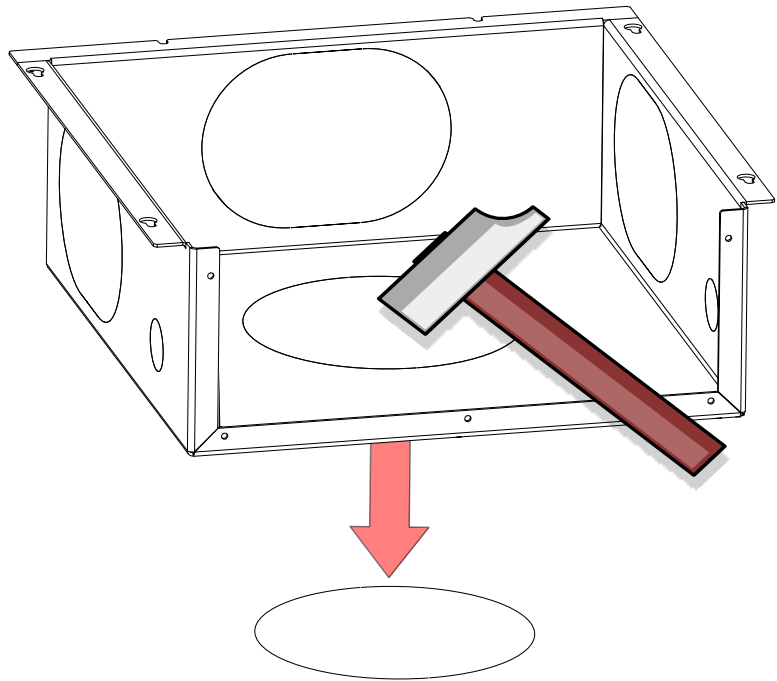

8

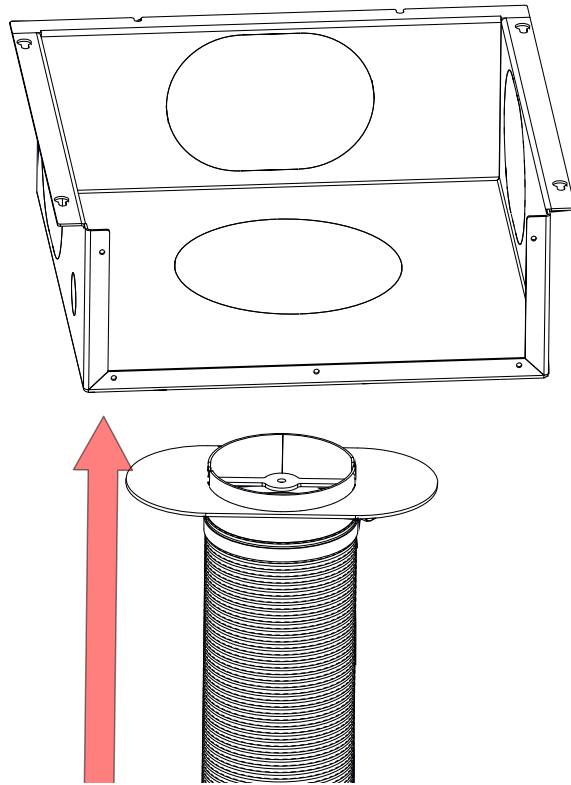

9

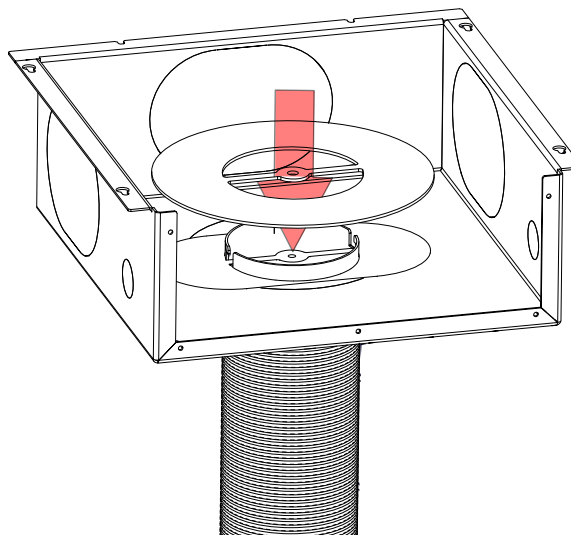

10

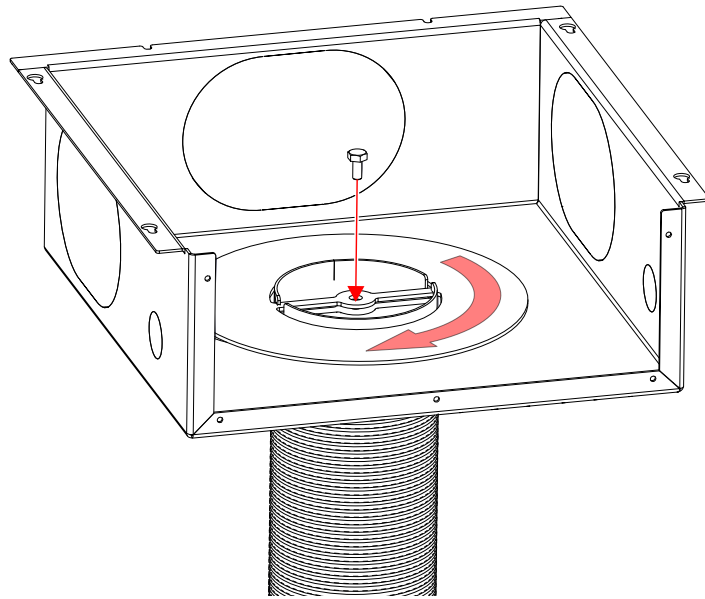

11

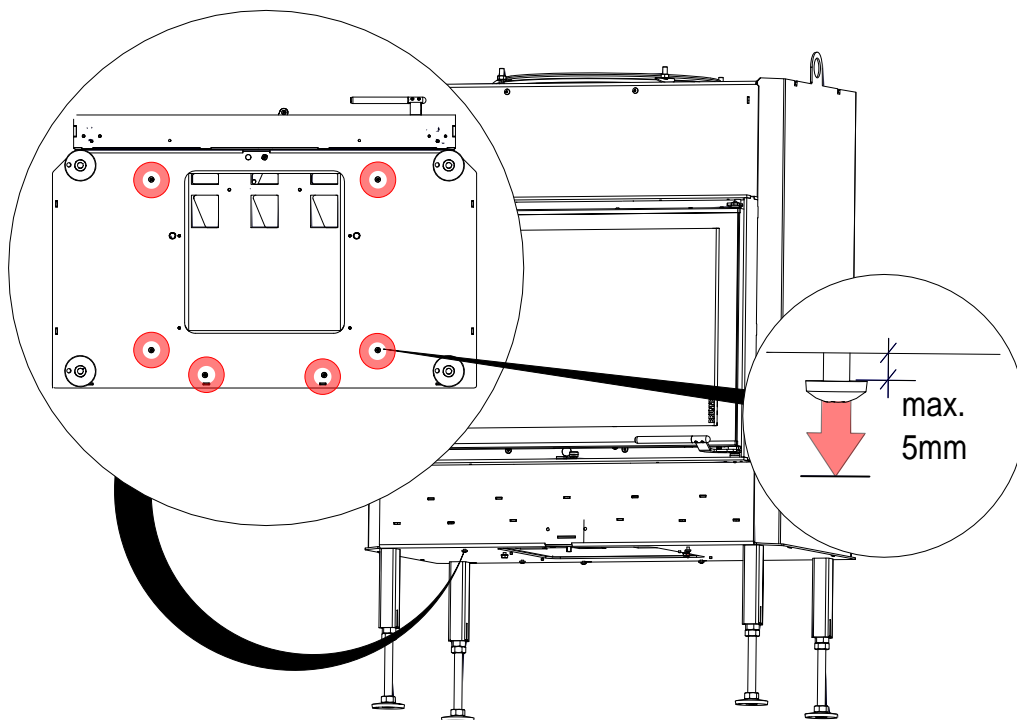

12

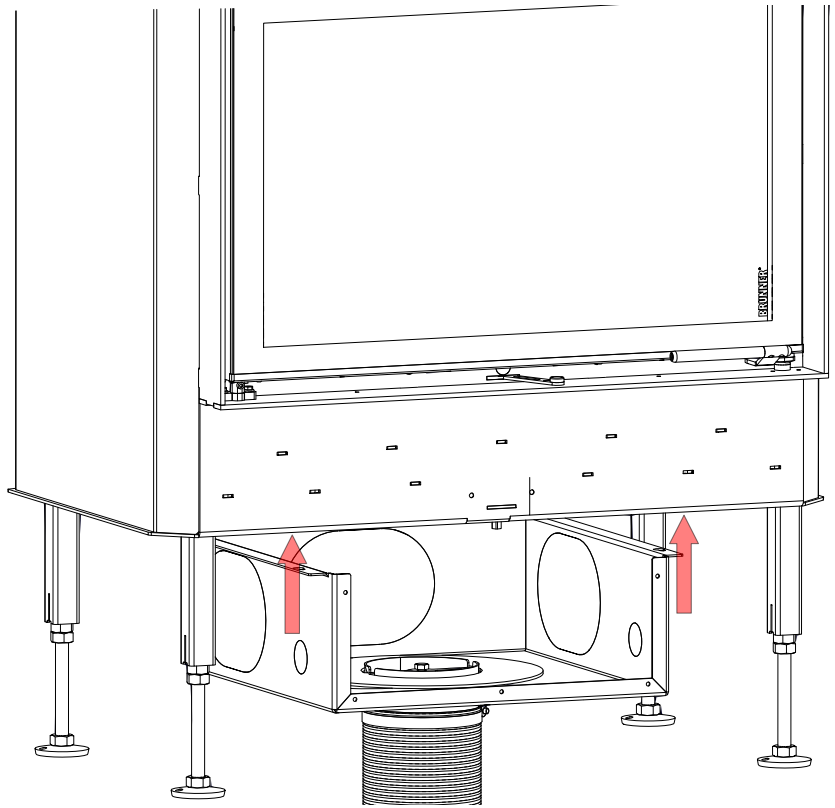

13

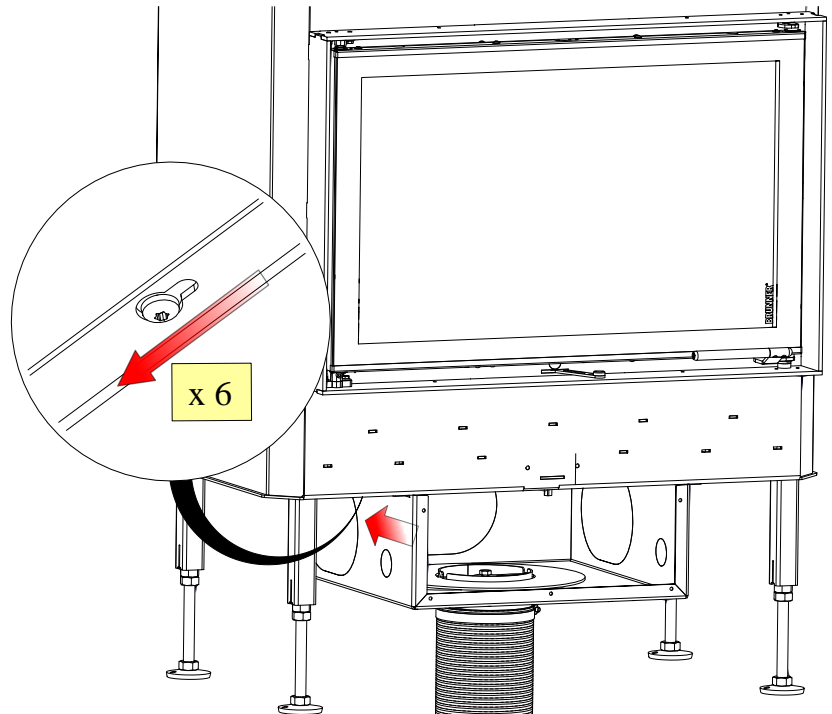

14

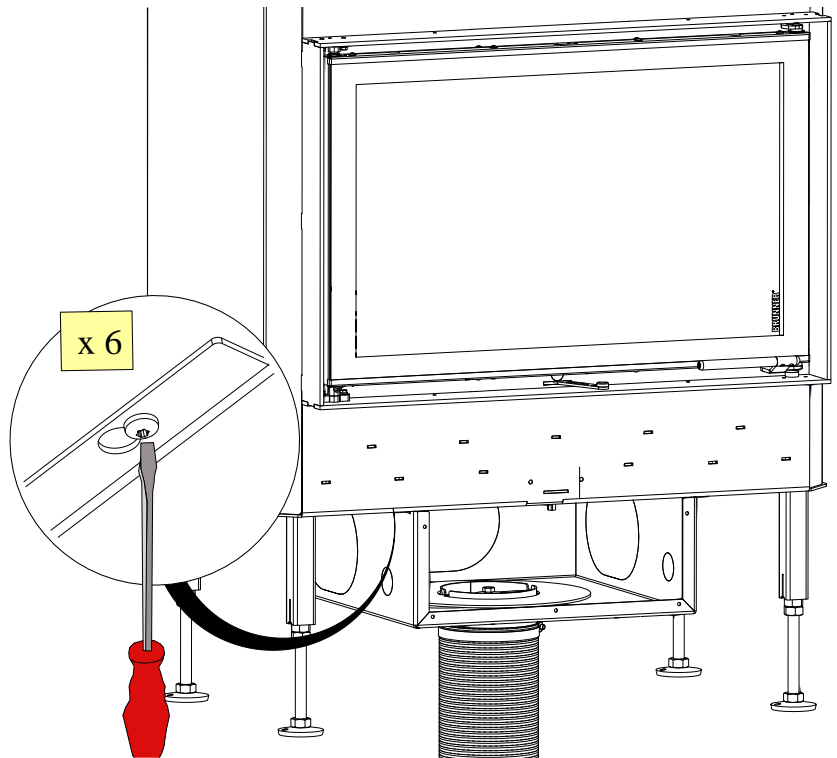

15

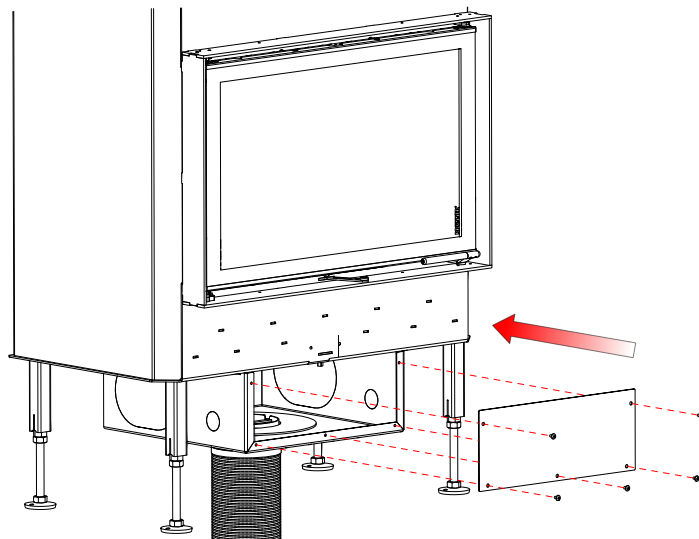

6.3.2 SIDE CONNECTION (S)

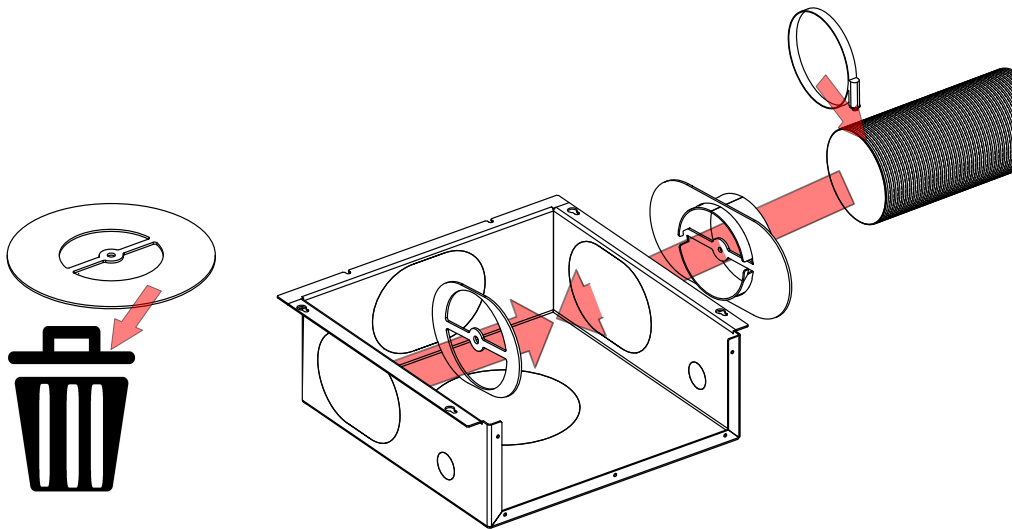

Im. 4: Summarised information

Workflow:

5

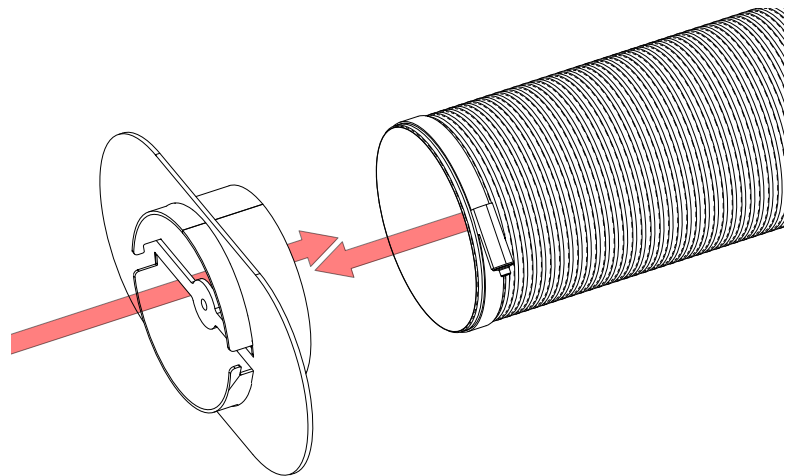

6

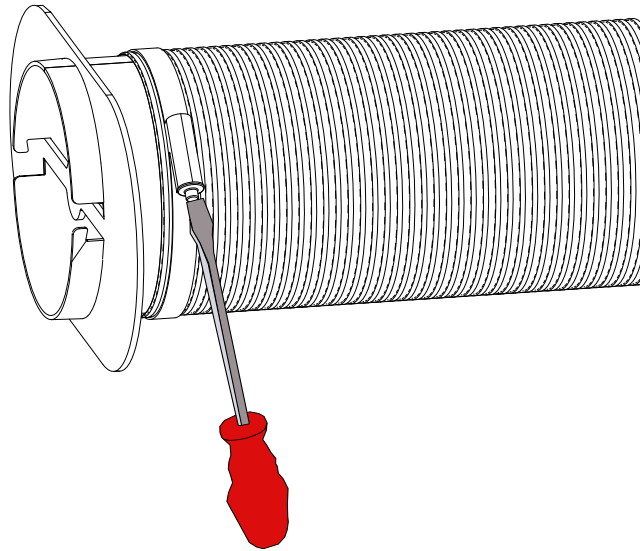

7

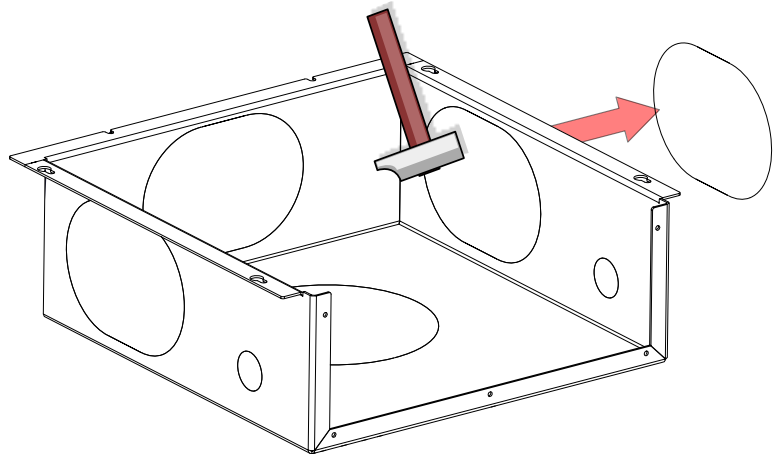

8

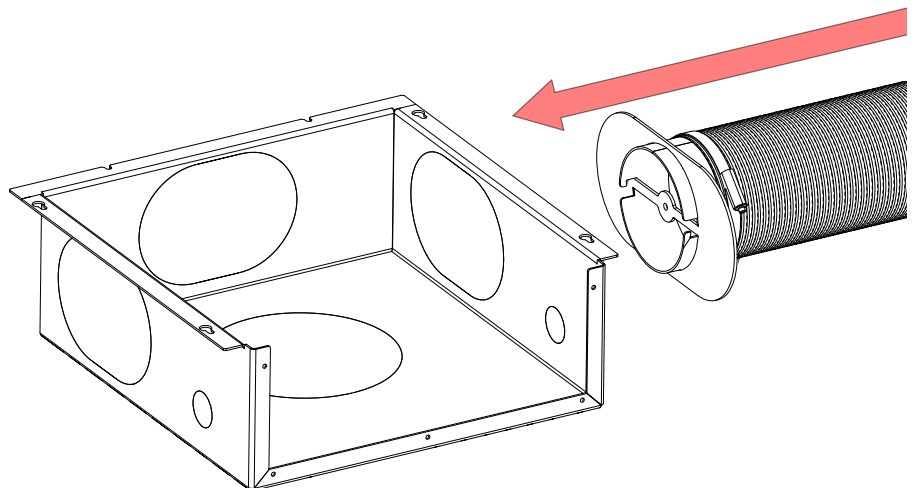

9

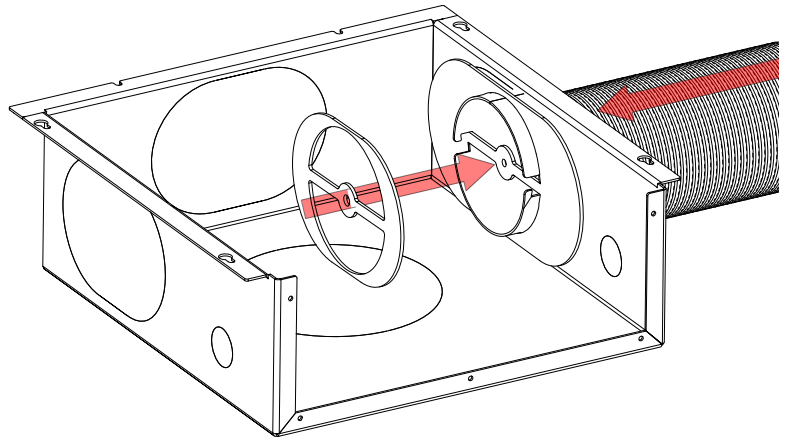

10

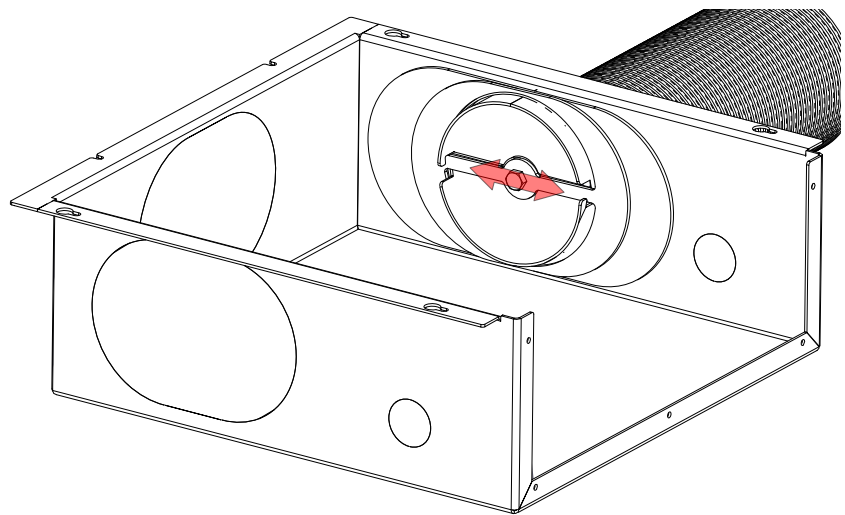
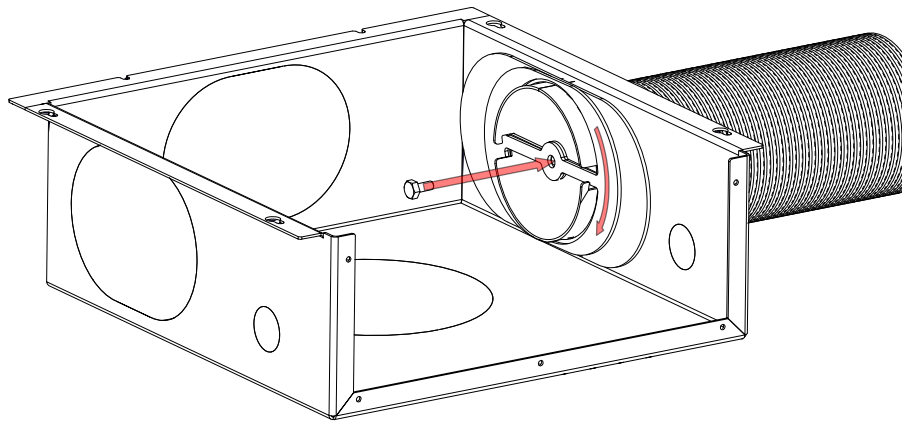

11

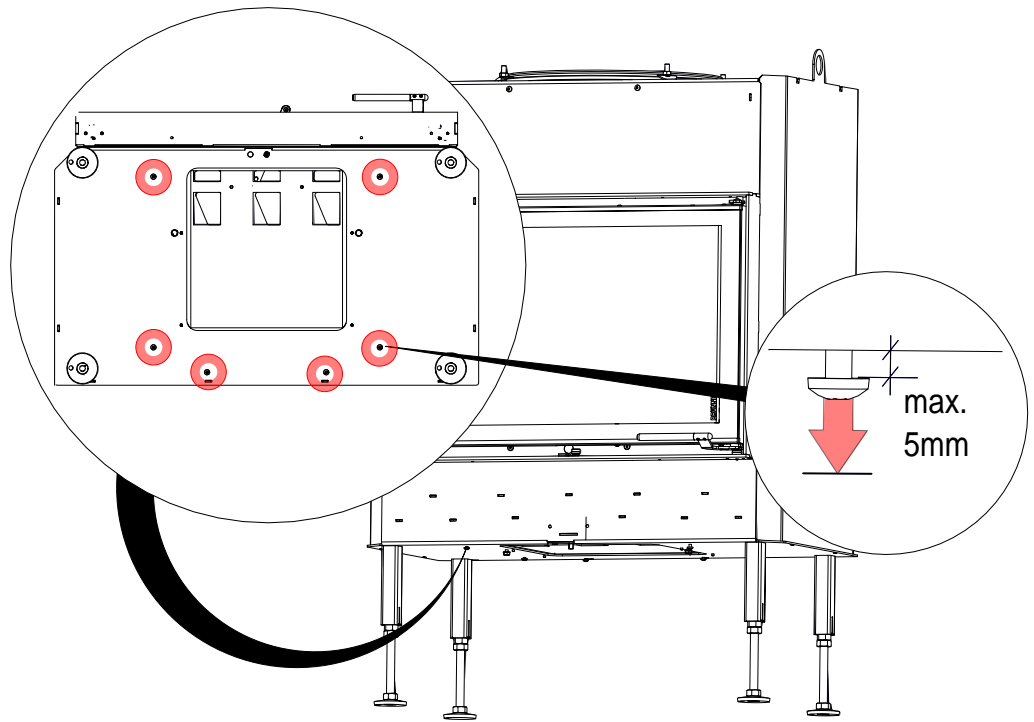

12

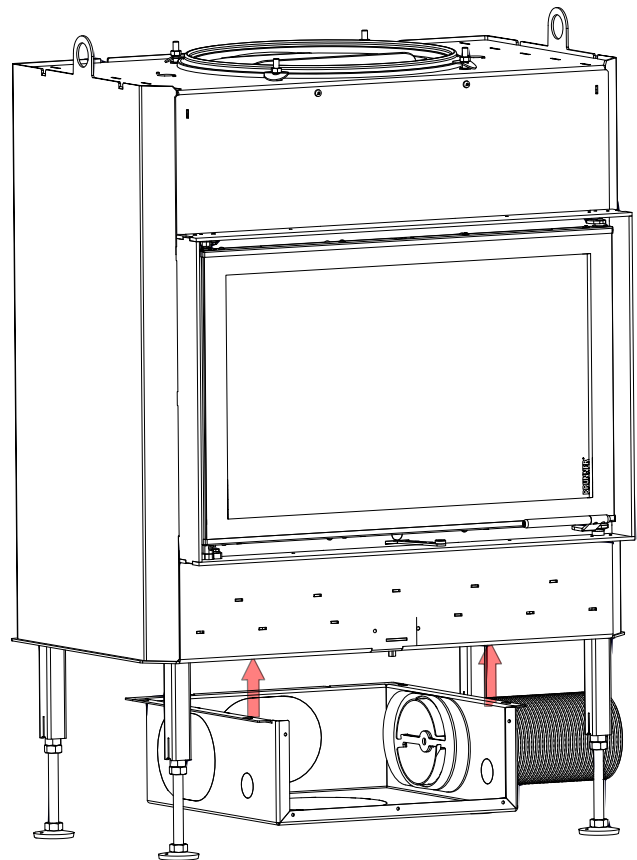

13

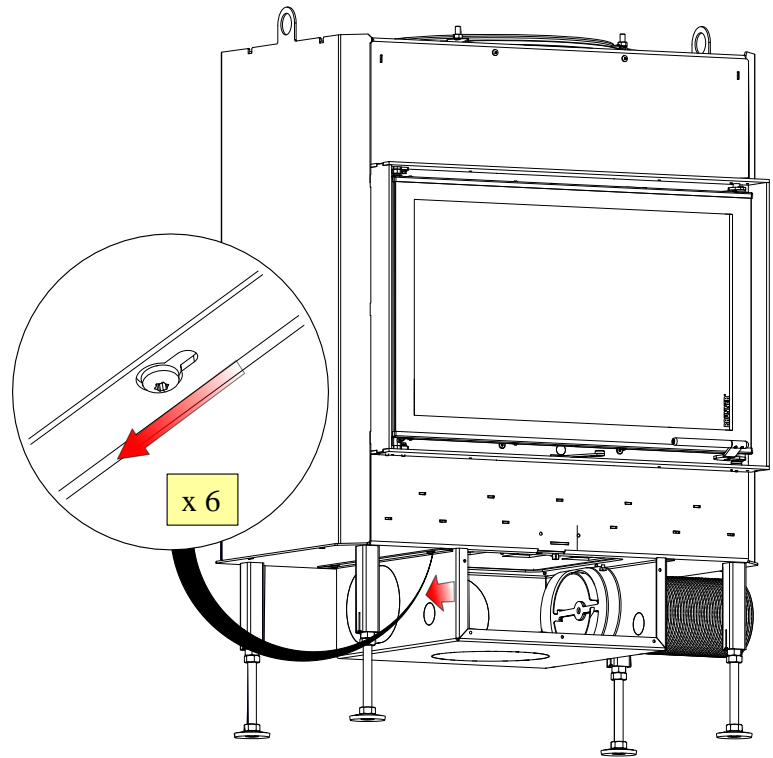

14

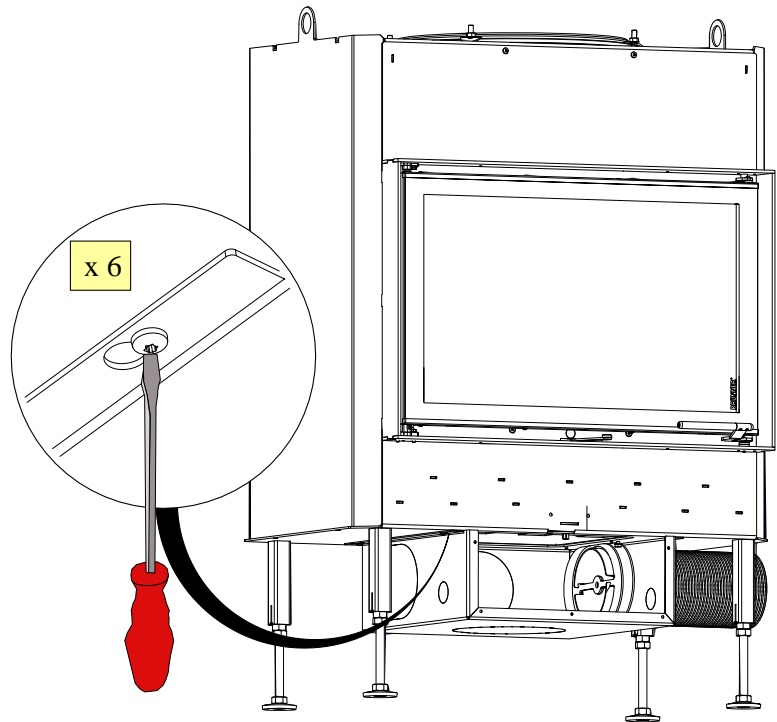

15

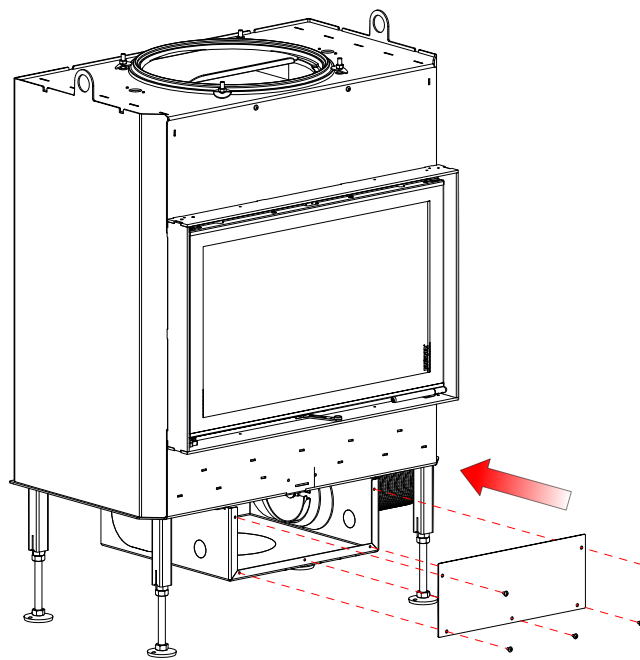

6.4 VARIANT WITH EAS OR EOS

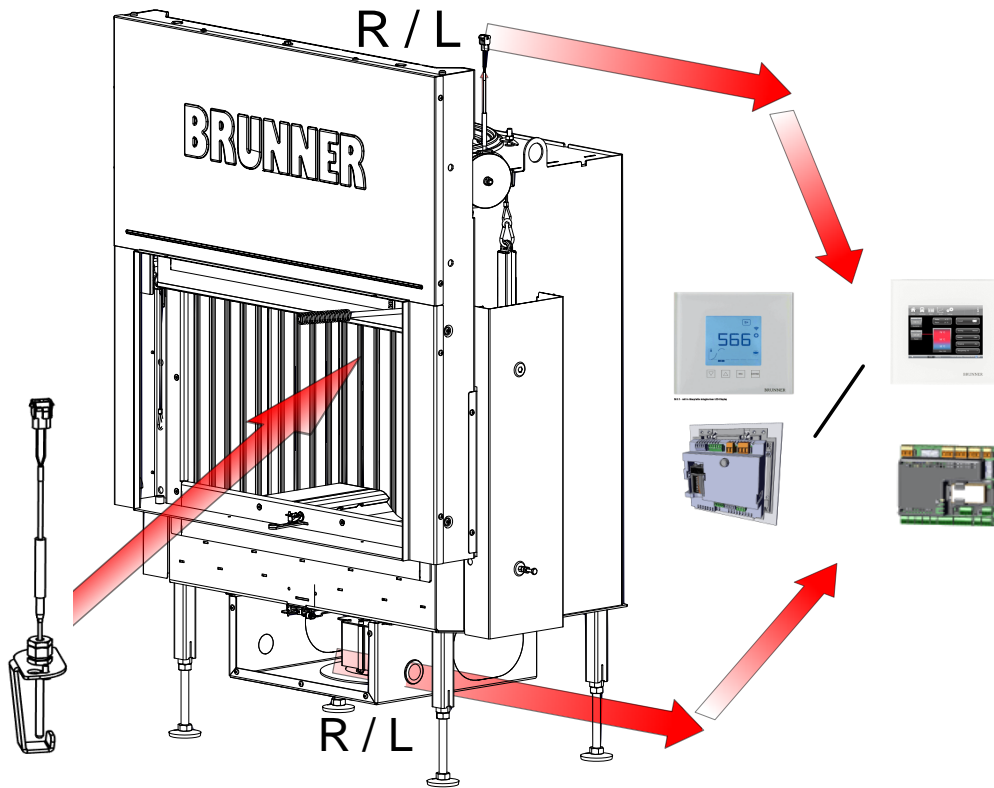

Im. 5: Summarised information



Software version:

EOS 8 - version > V1.35

EAS 3 - version > V3.24



CAUTION! risk of crushing

When working on the flap, on the turntable or sliding plate for supply / exhaust air regulation, as well as on their mechanics, the control unit (EAS / EOS) must be disconnected from the supply voltage (230VAC) before starting work. Wait until the drive has been fully powered up via the battery of the control unit (maximum running time 2 minutes).

Workflow:

1

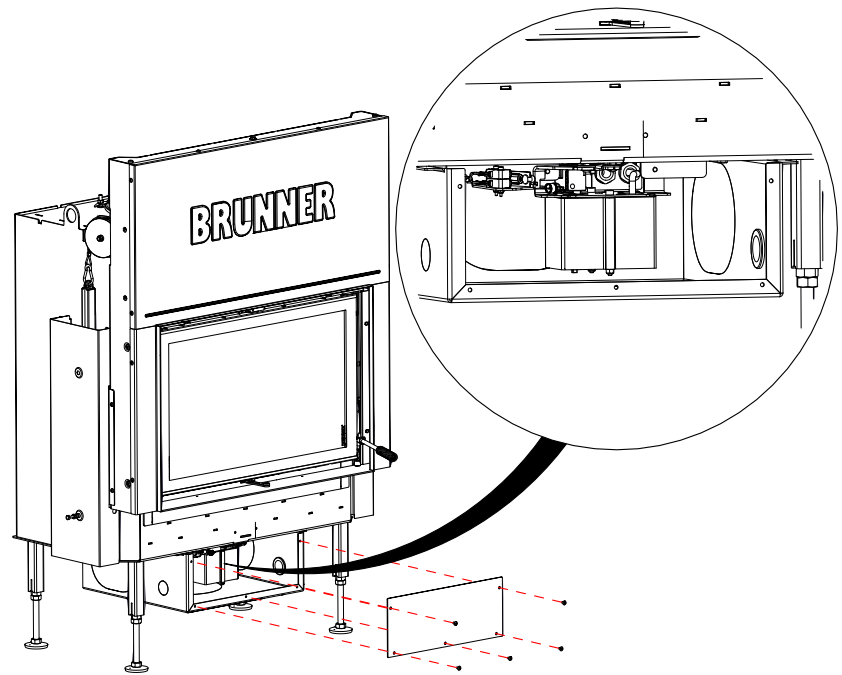

2

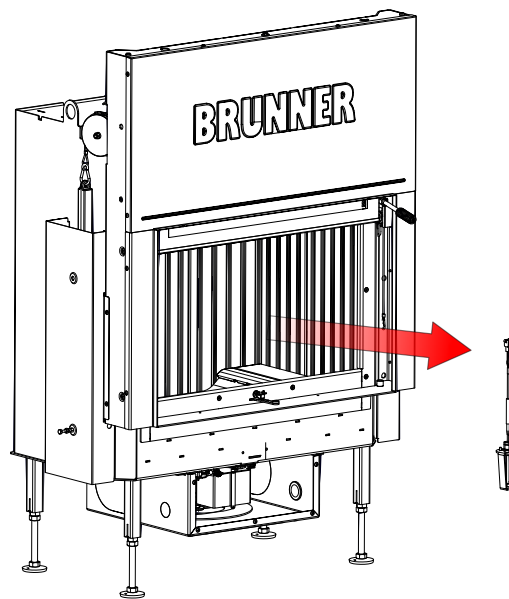

Make the electrical connection

Variants:
cable routing right side or left side

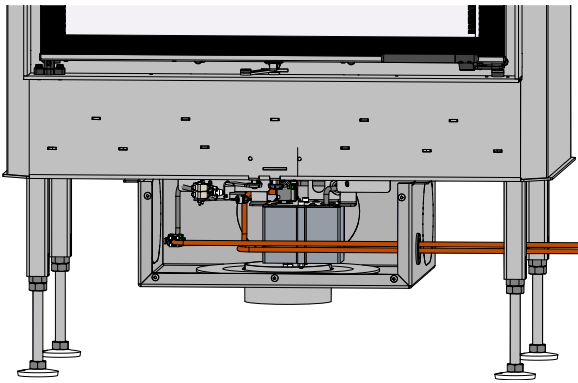

Im. 6: cable routing right side

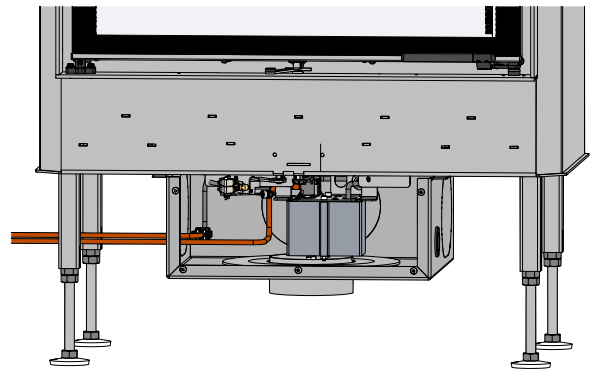

Im. 7: cable routing left side

3

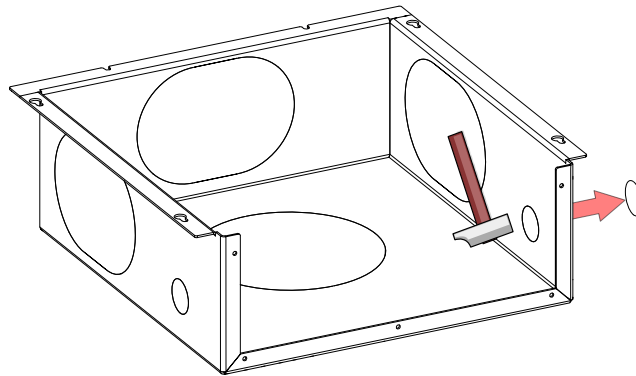

4

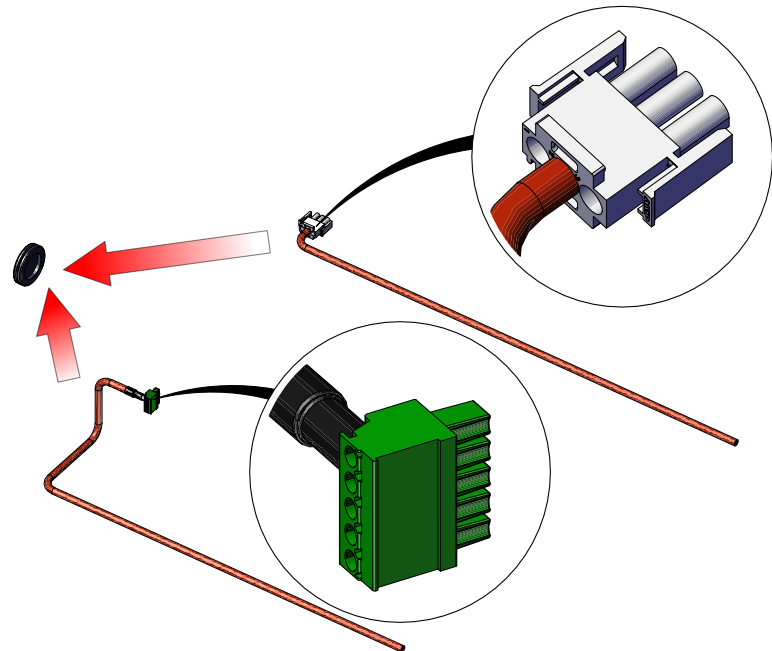

5

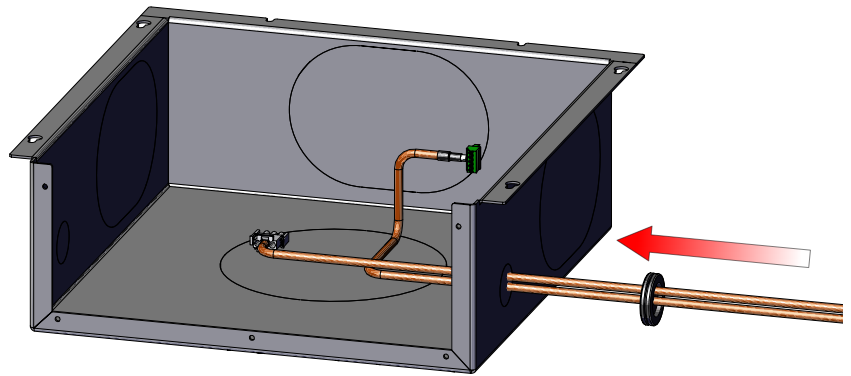

INFO: Access

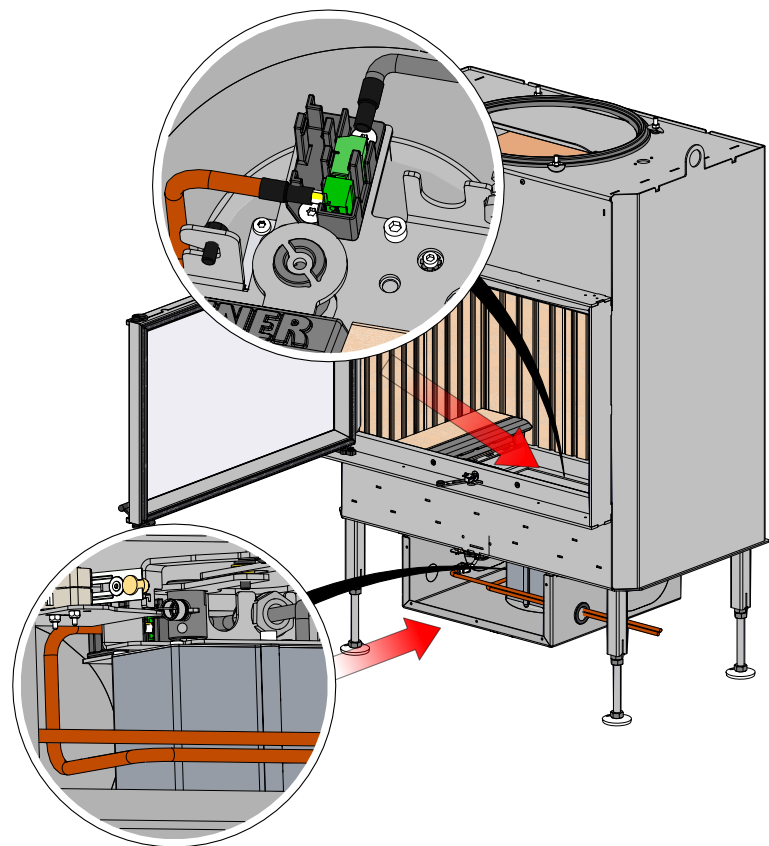

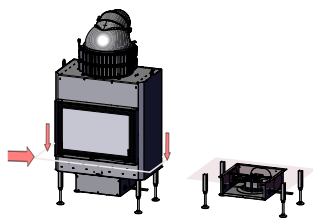

6

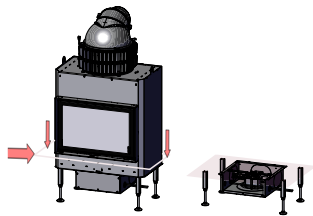
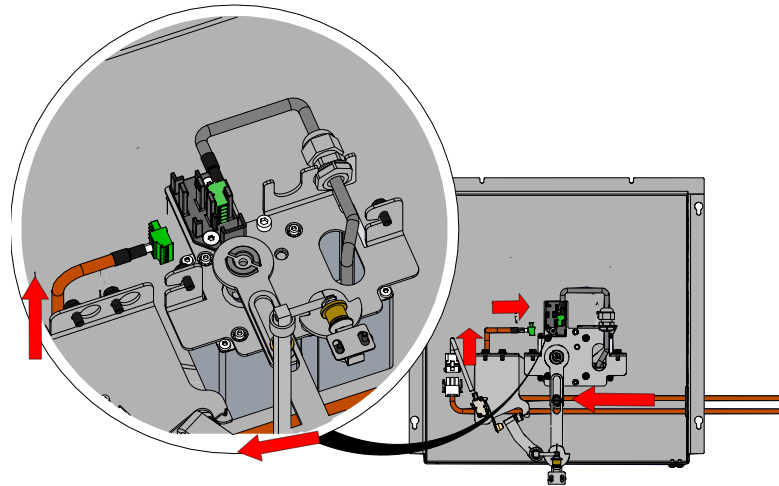

7

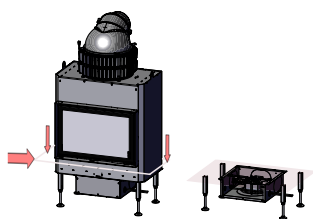
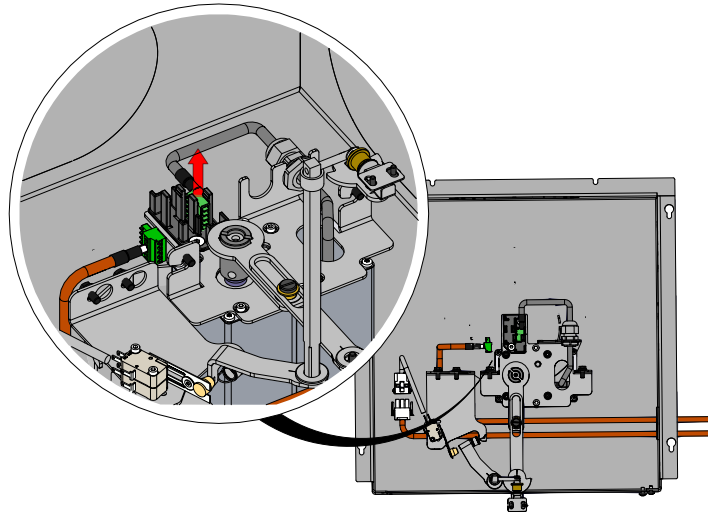

8

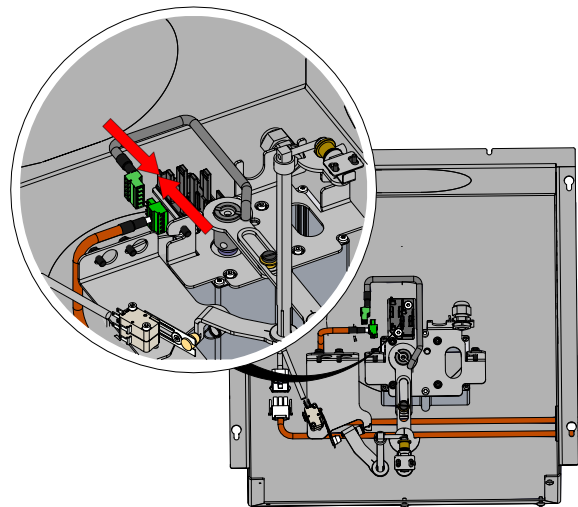

9

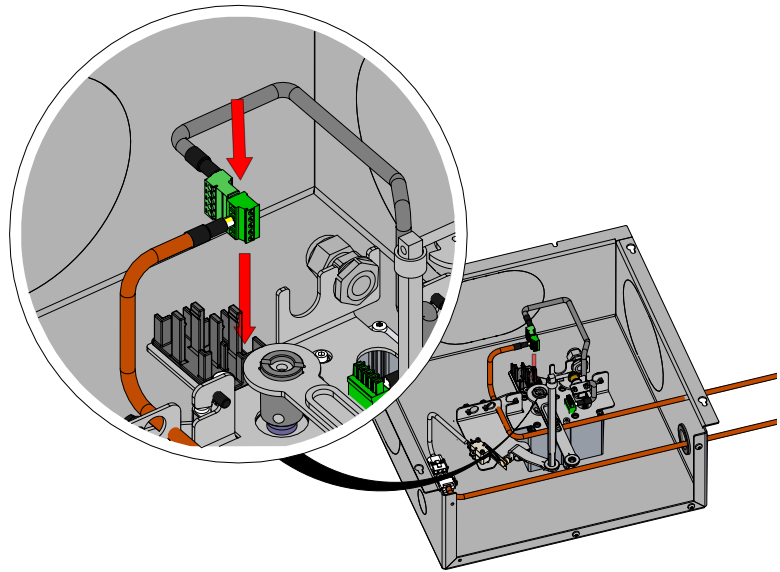

10

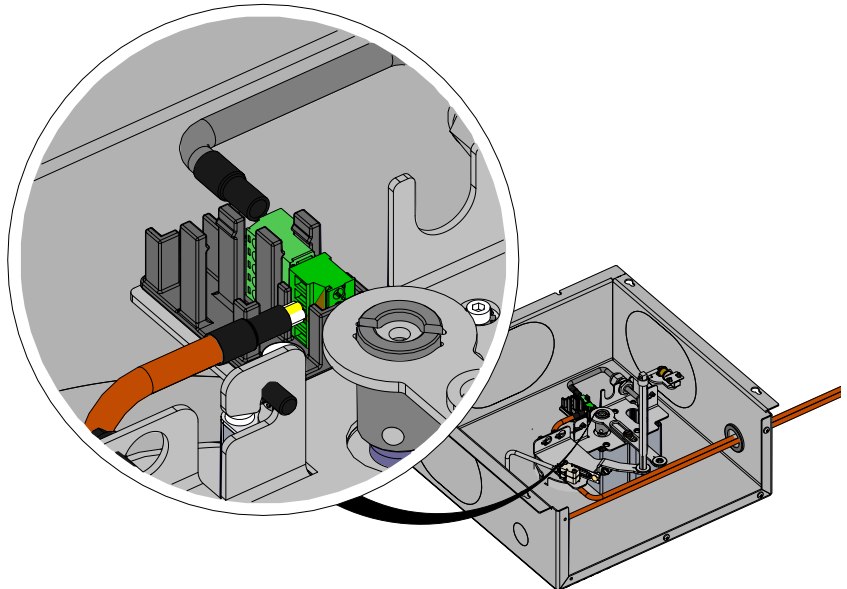

11

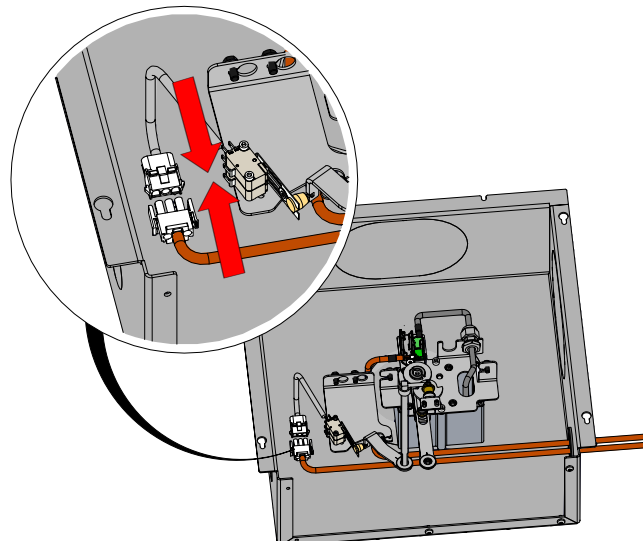

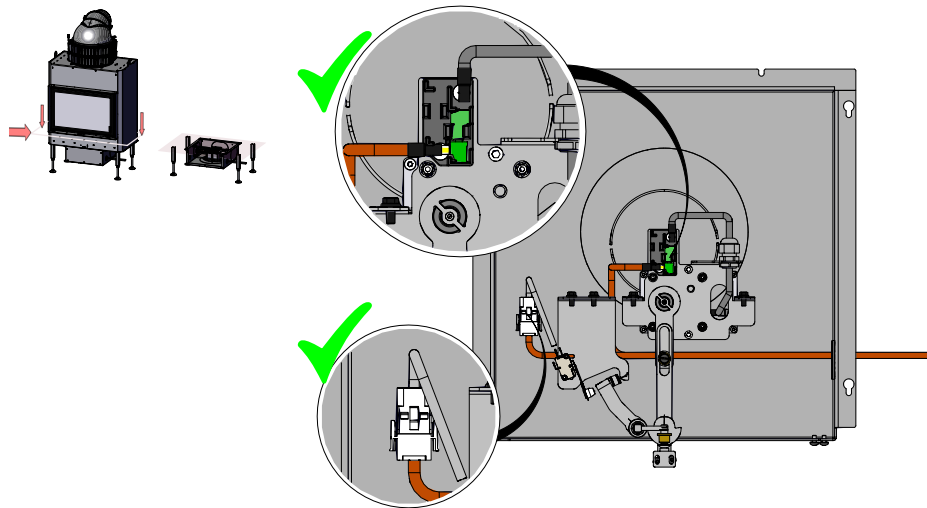

12

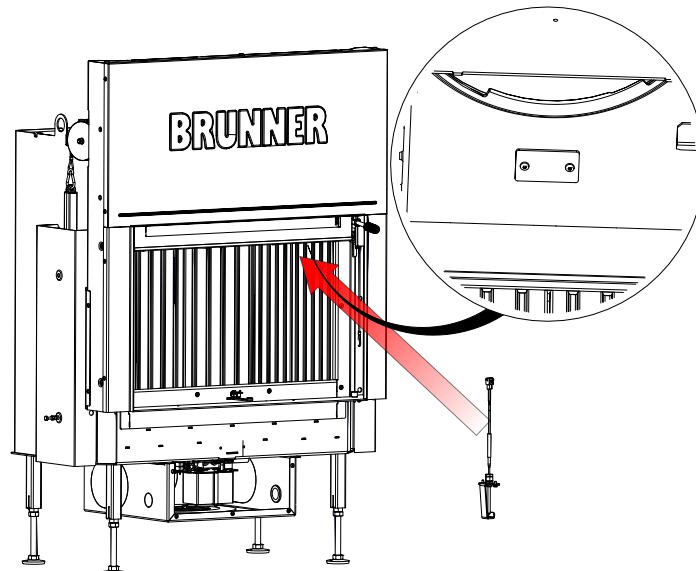

Variants cable routing - Thermocouple: right side or left side

right side:

left side:

i

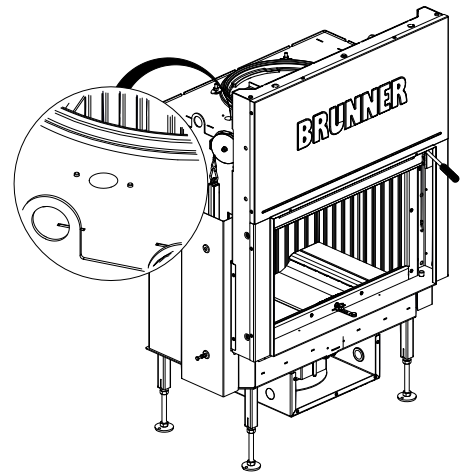
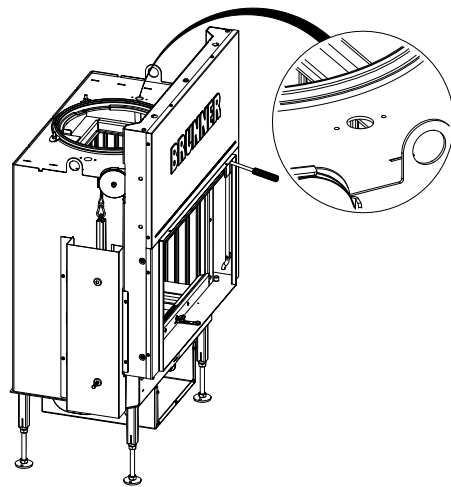

13

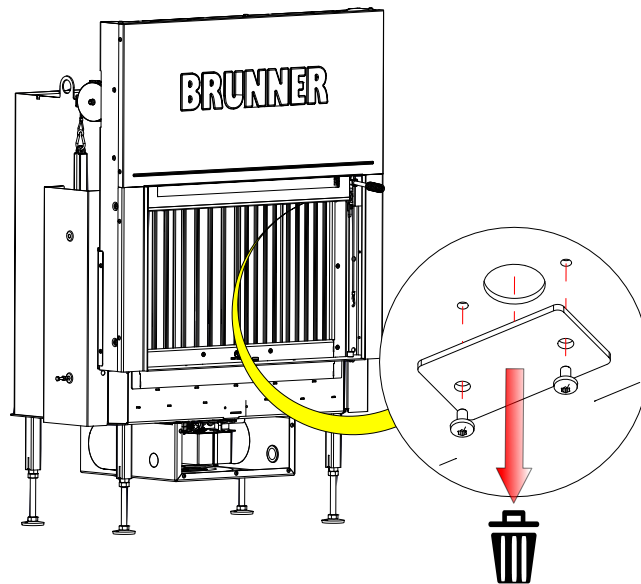

14

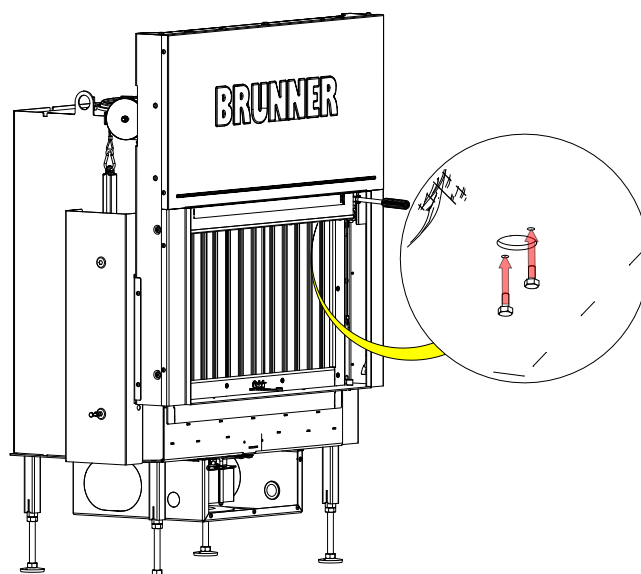

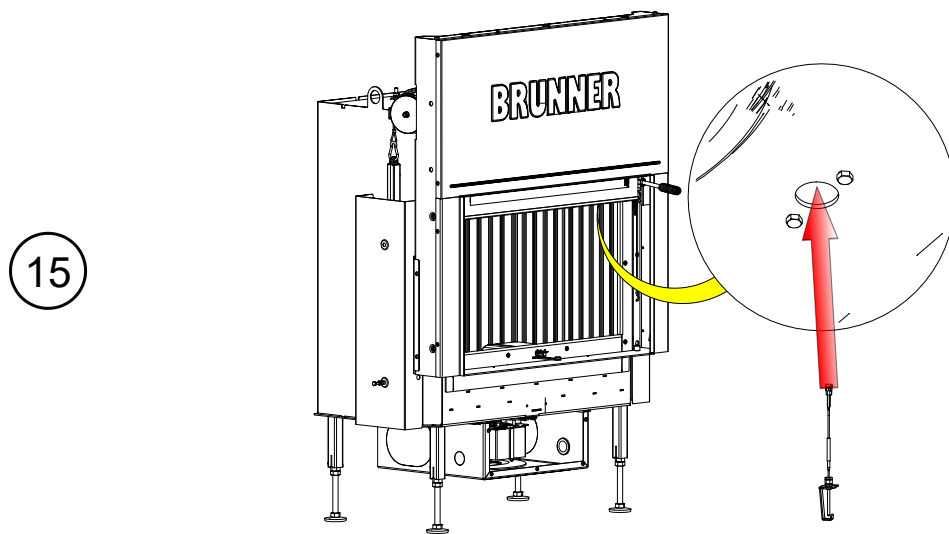

i Do not overtighten the screws!

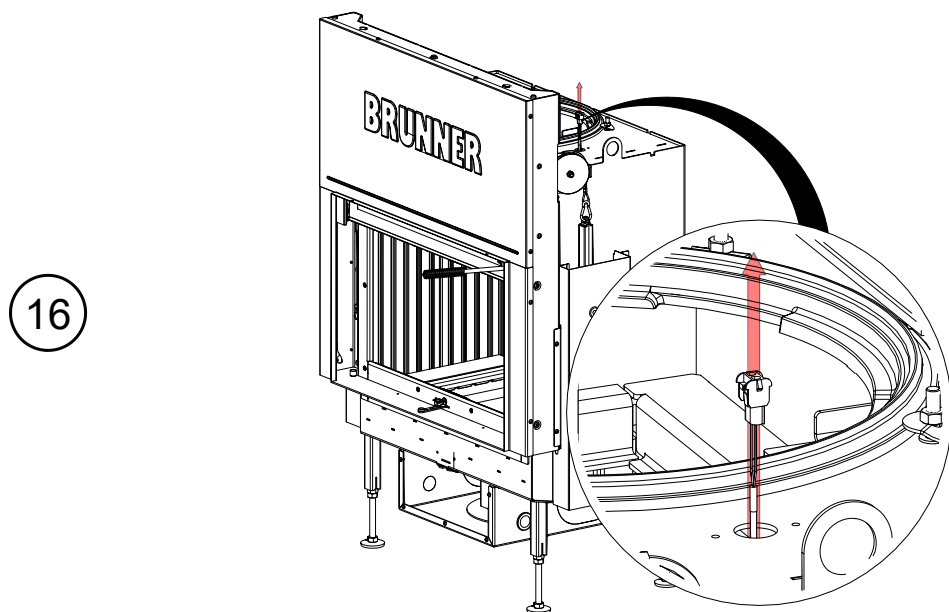

17

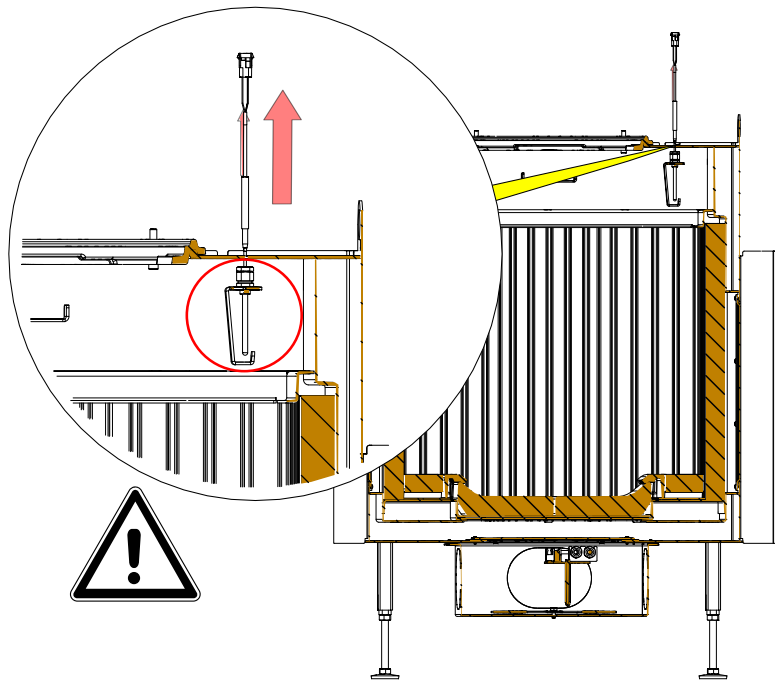
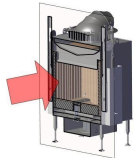

18

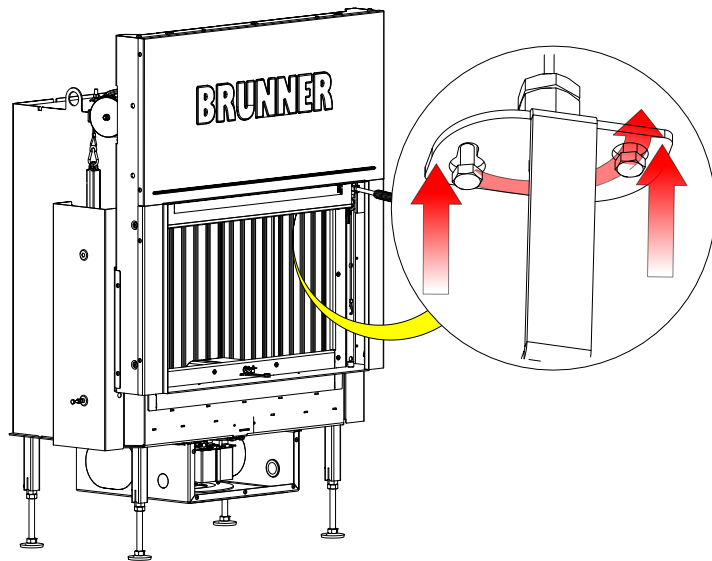

**Variant: Ther-
mocouple
right side**

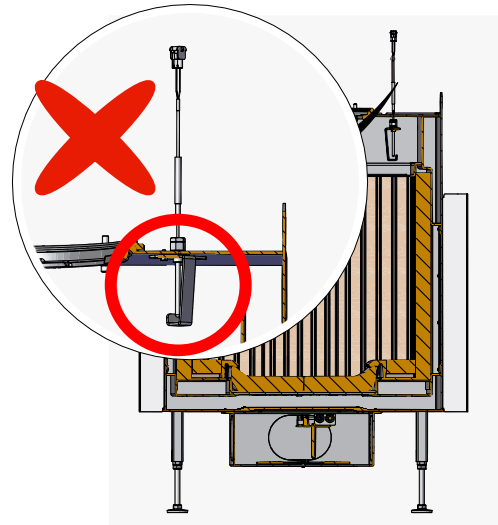
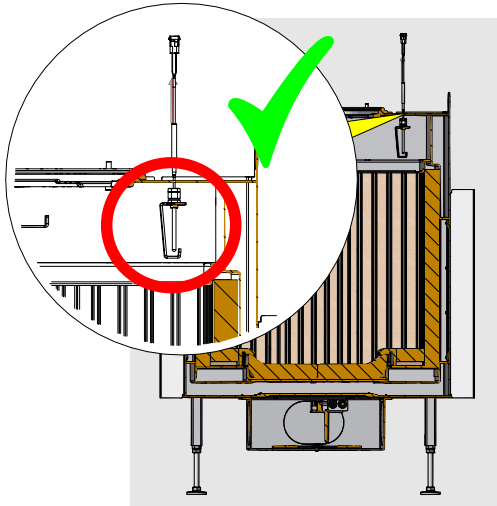
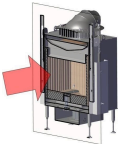

**Variant: Ther-
mocouple
left side**

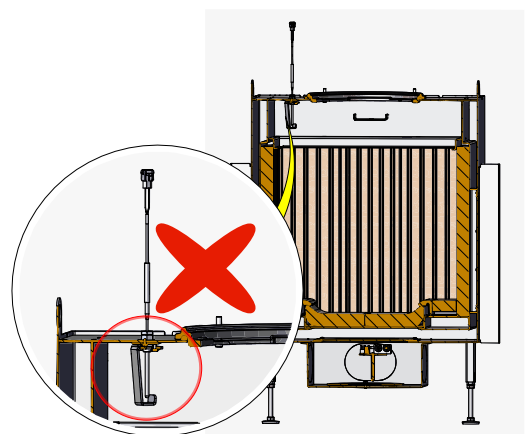
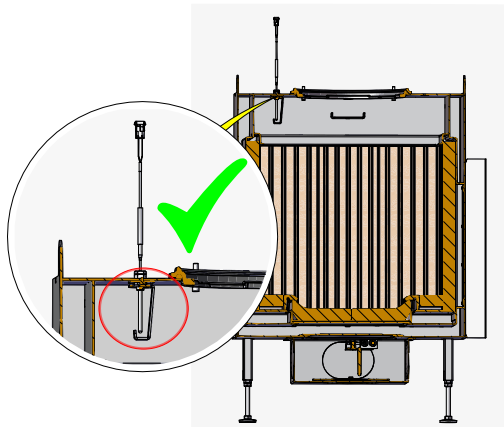
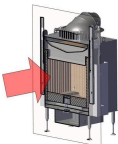

19

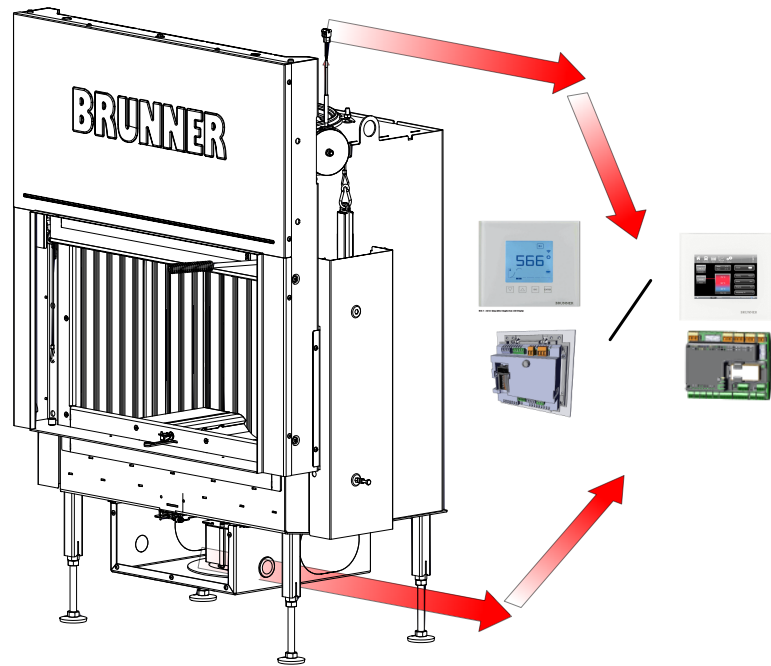

7 FITTING: CATALYTIC CONVERTER

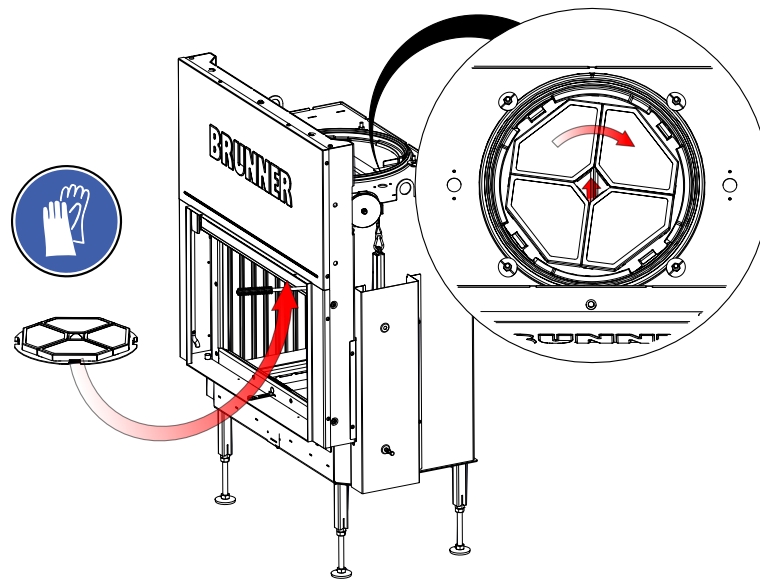

Im. 8: Summarised information

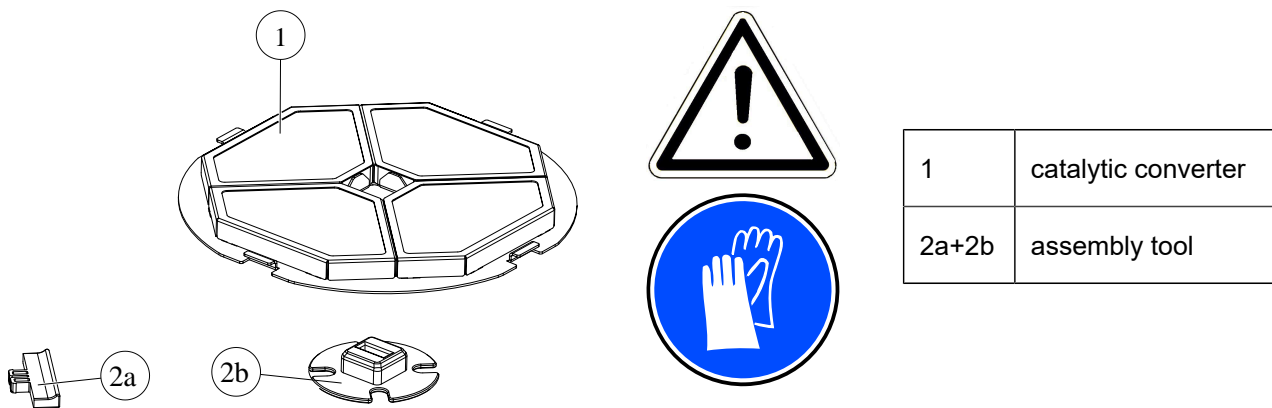

Workflow:

1

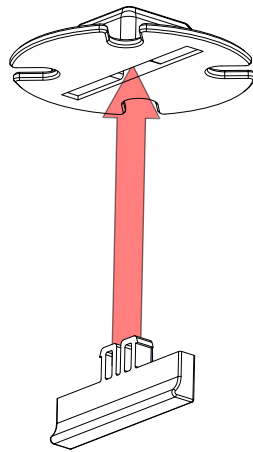

2

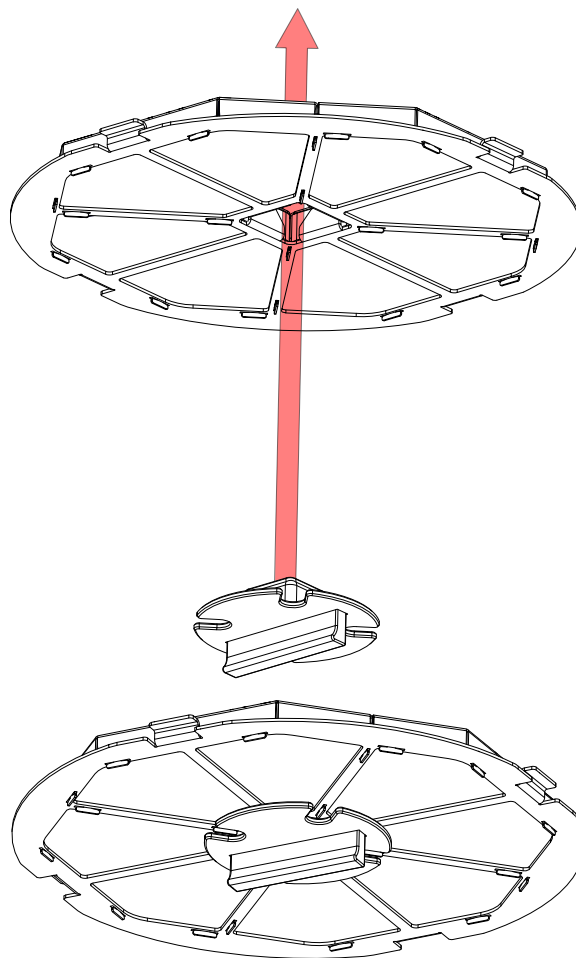

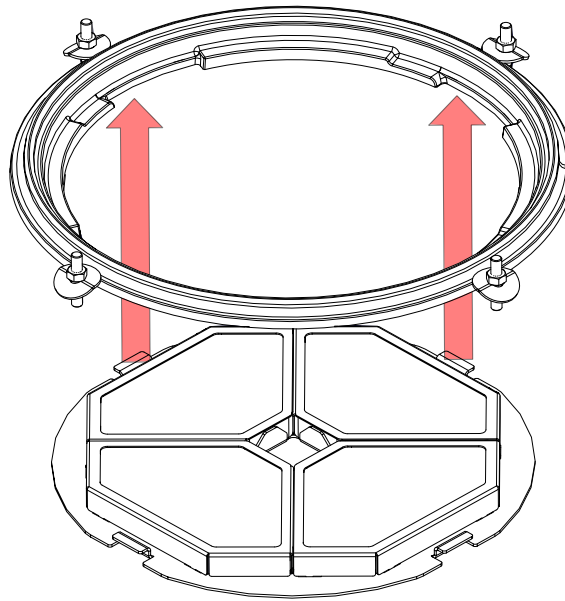

3

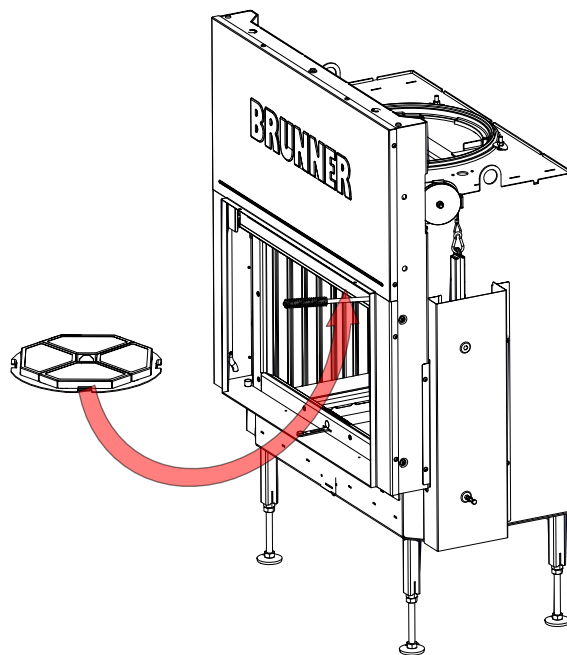

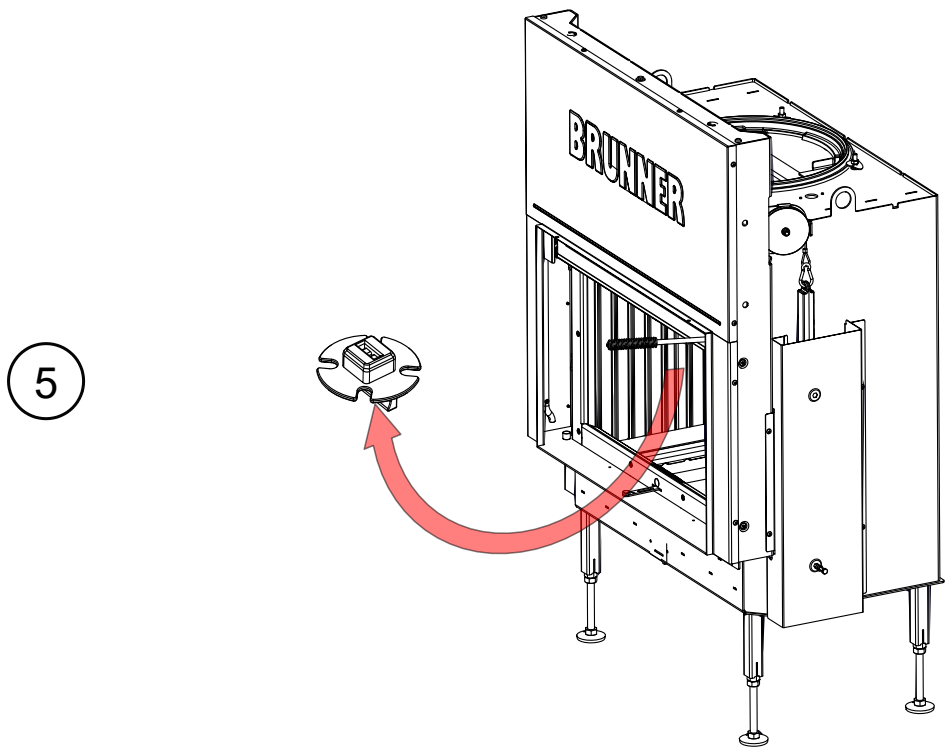
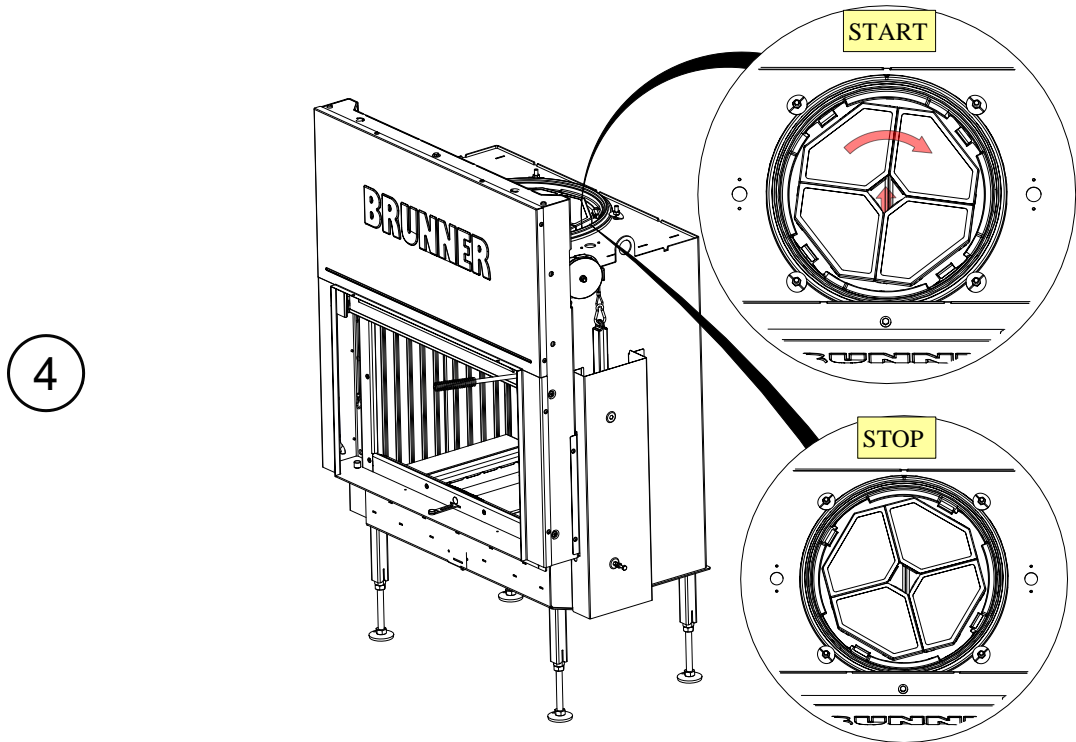

8 FITTING: DEFLECTION - COMBUSTION CHAMBER

Summarised information:

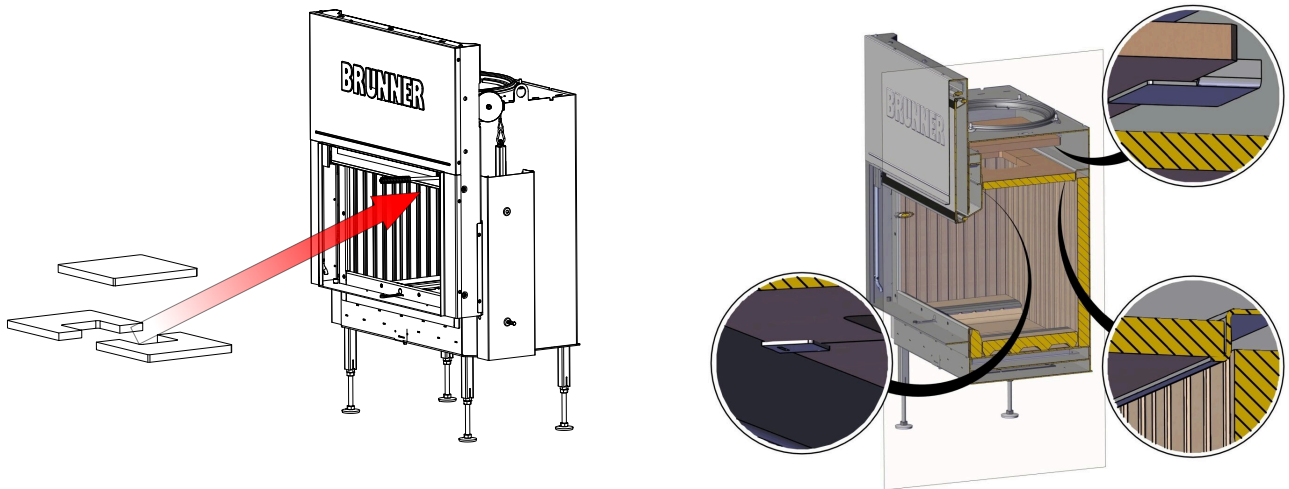

Montage

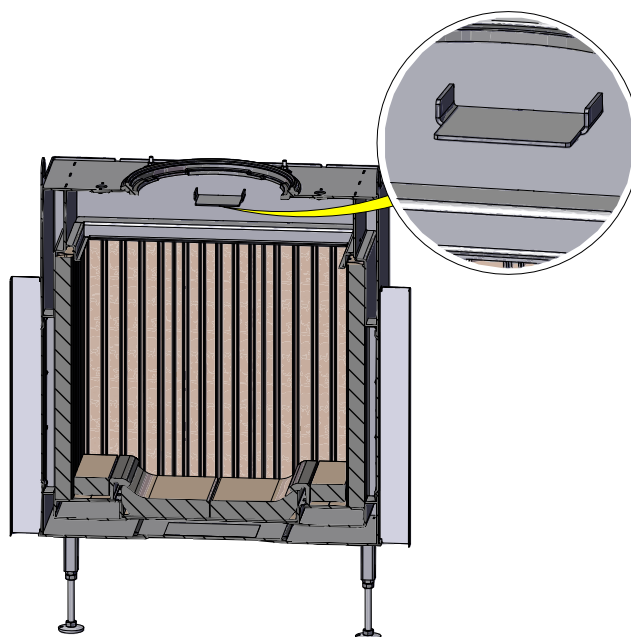
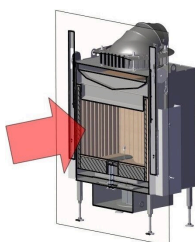
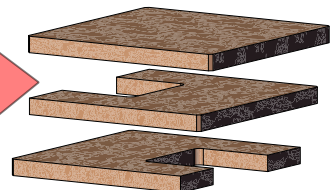
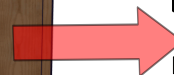

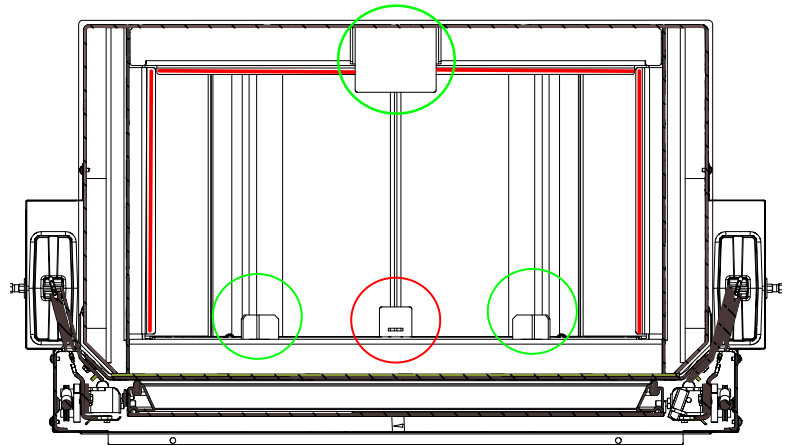
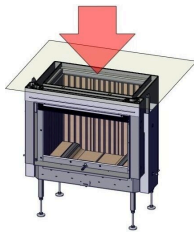

Im. 9: Support points for the deflection plates

Workflow:

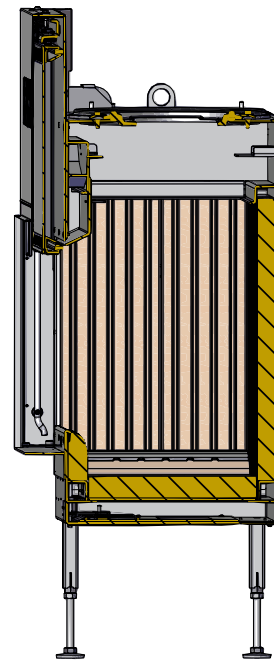
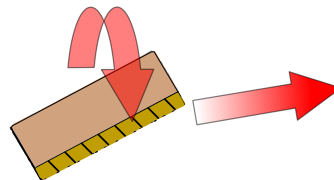
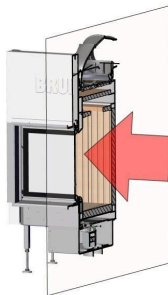

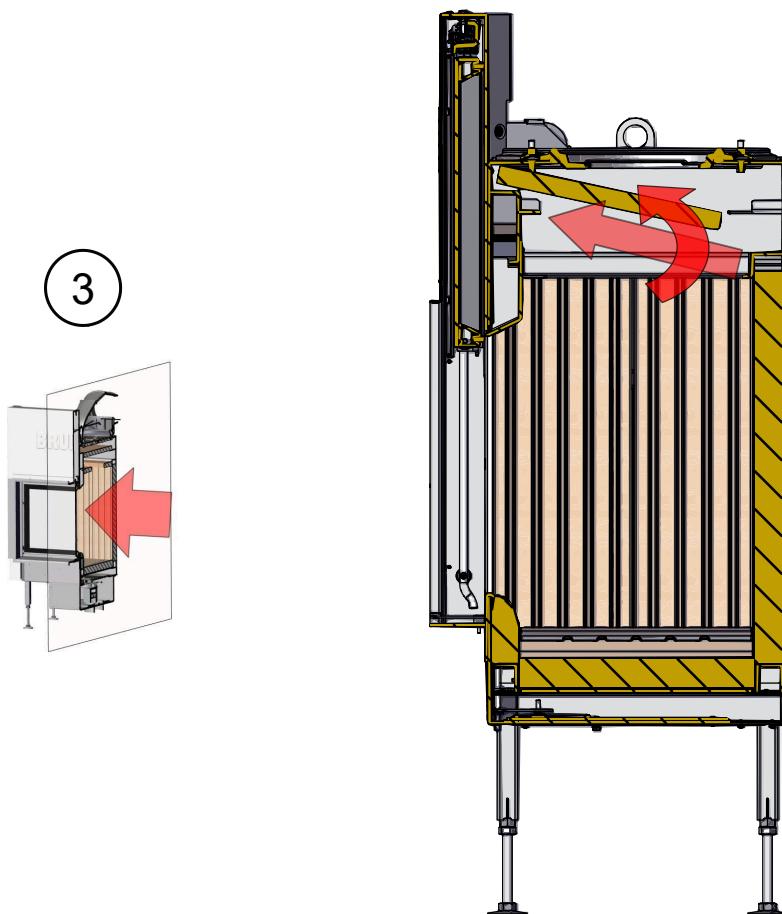
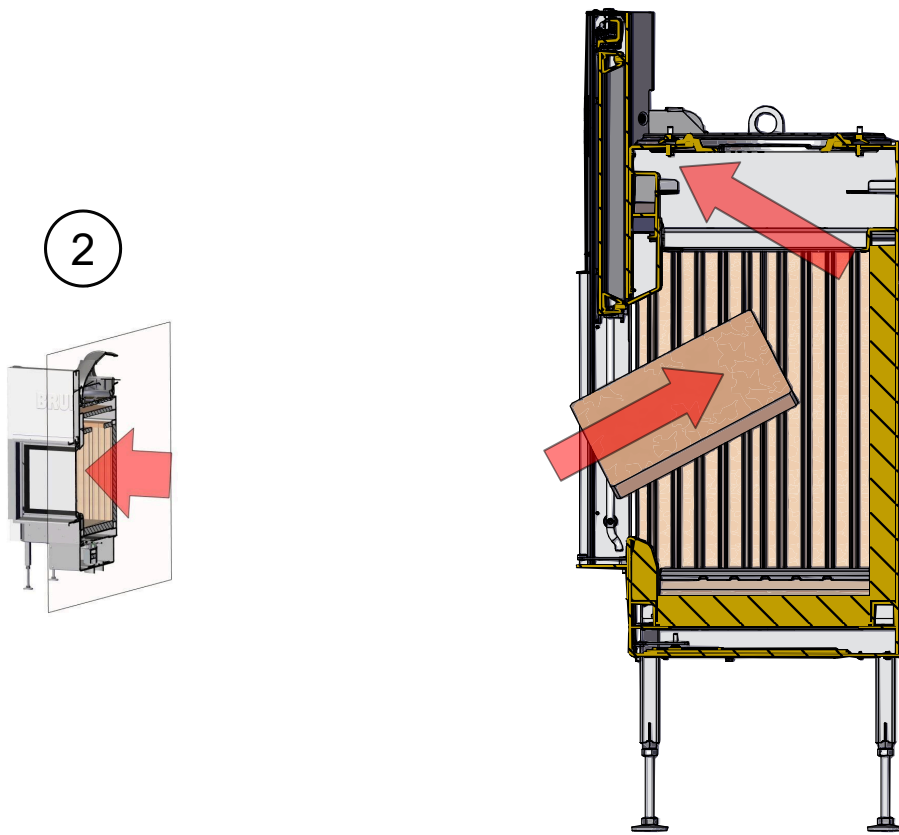

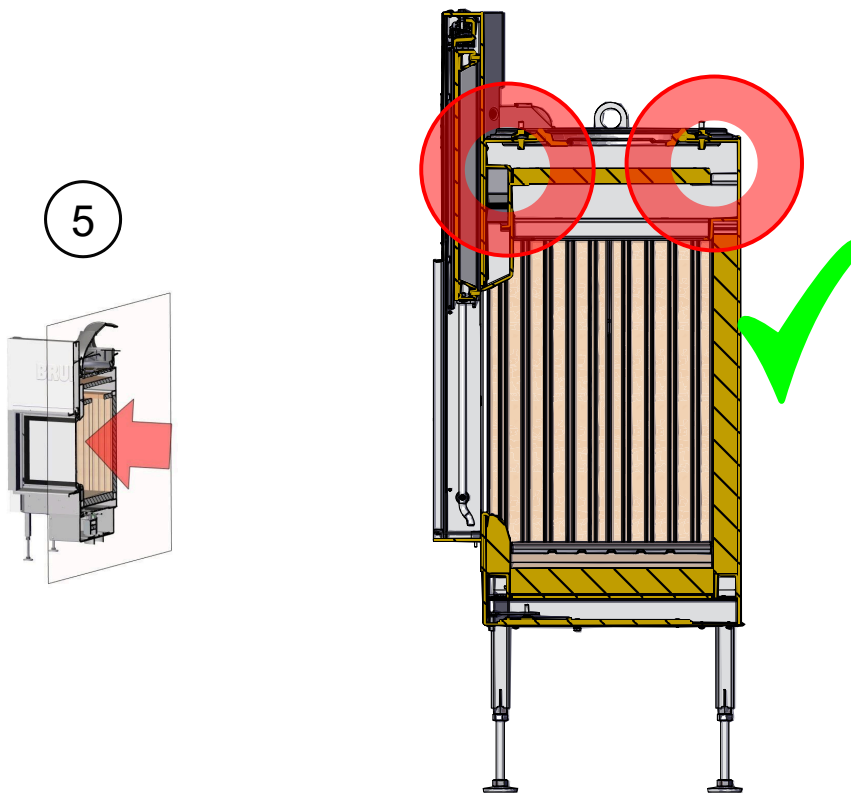
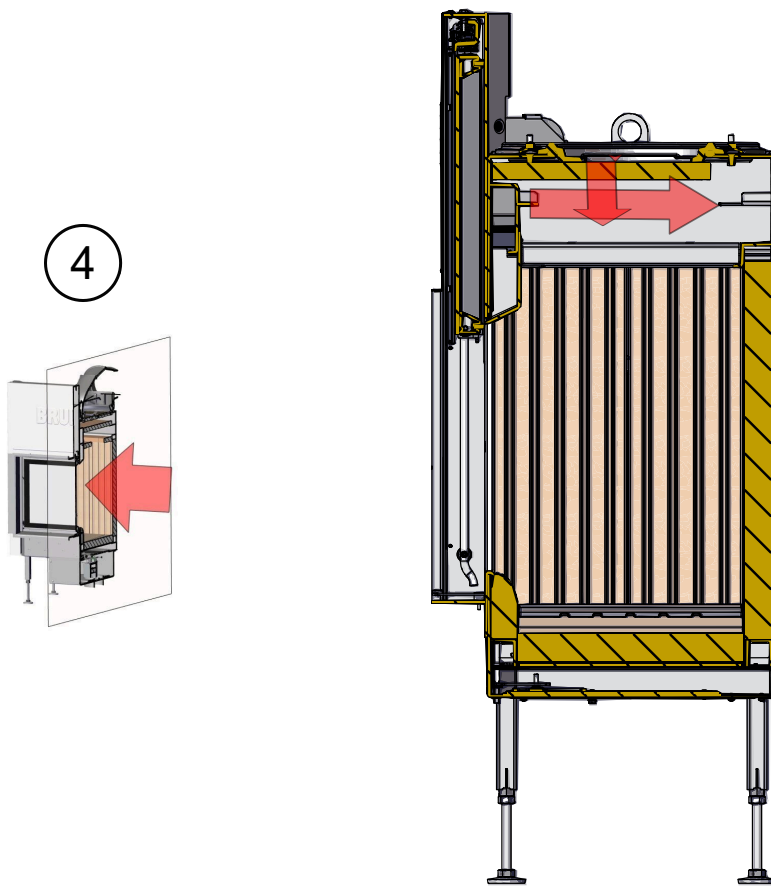

6

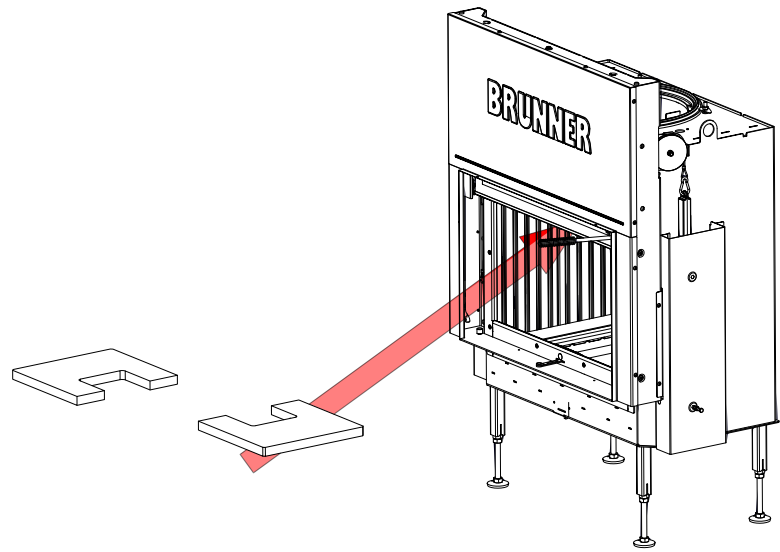

7

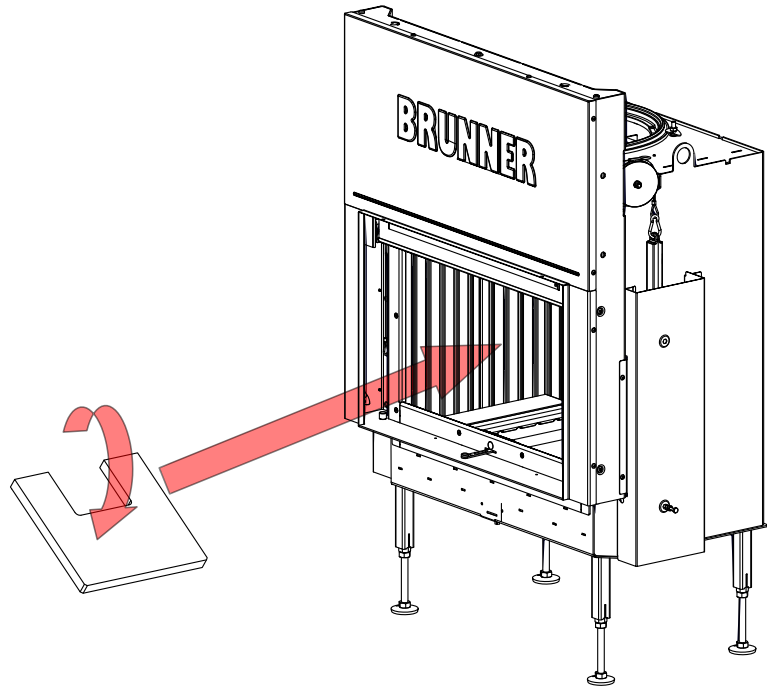

8

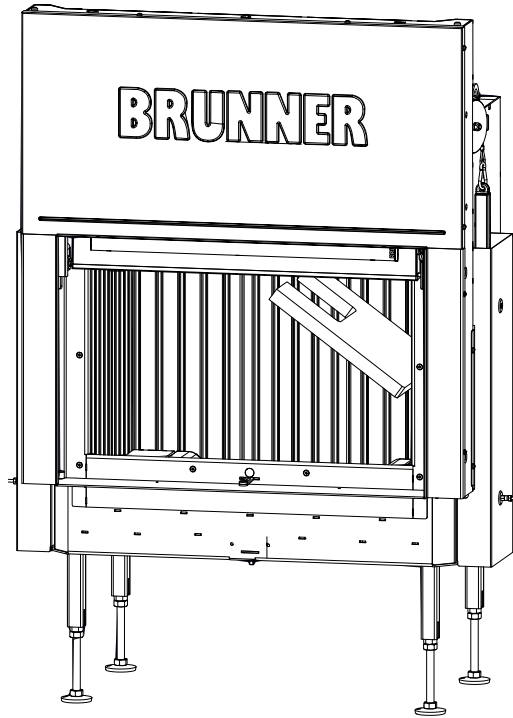

9

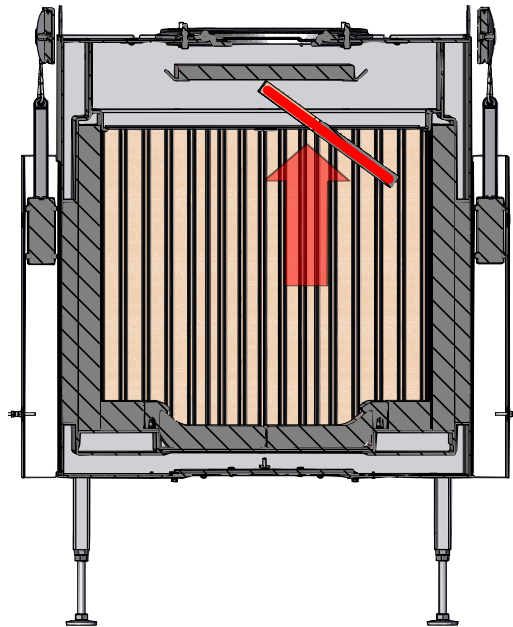
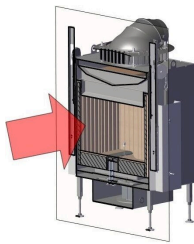

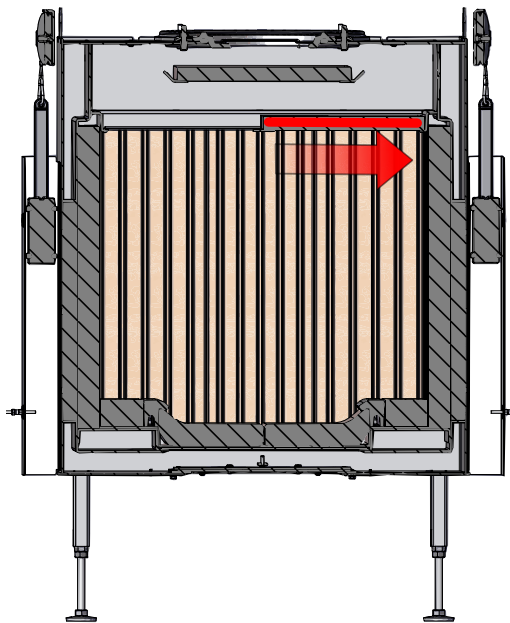
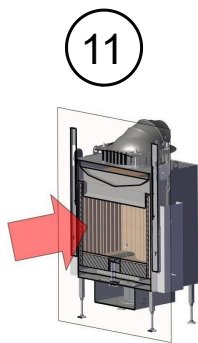
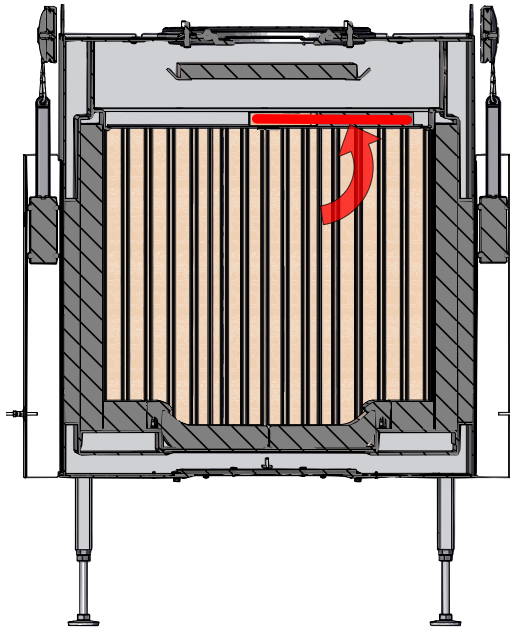
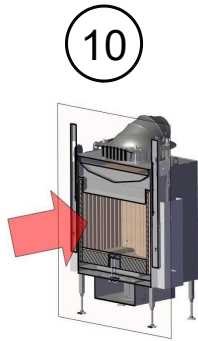

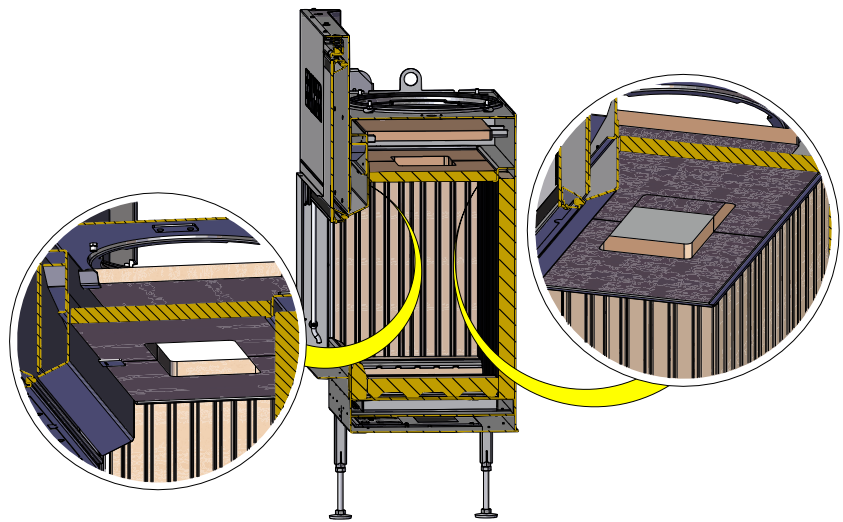
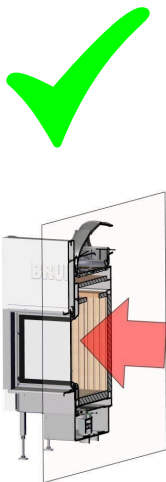
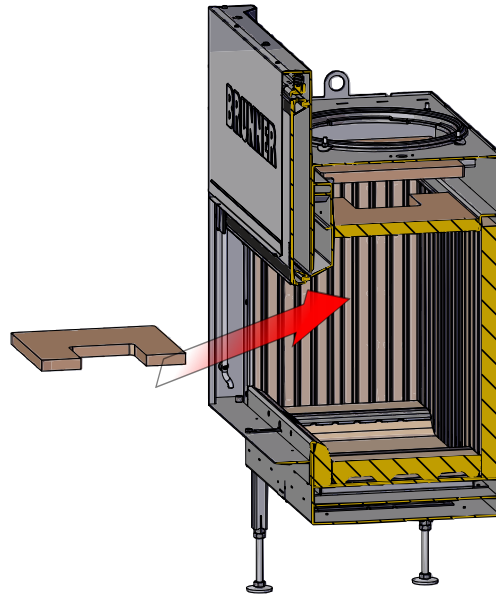
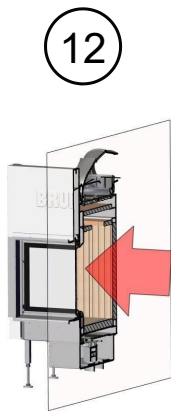

9 VARIANTS HEAT EXCHANGER

9.1 CONNECTION WITH CATALYTIC CONVERTER

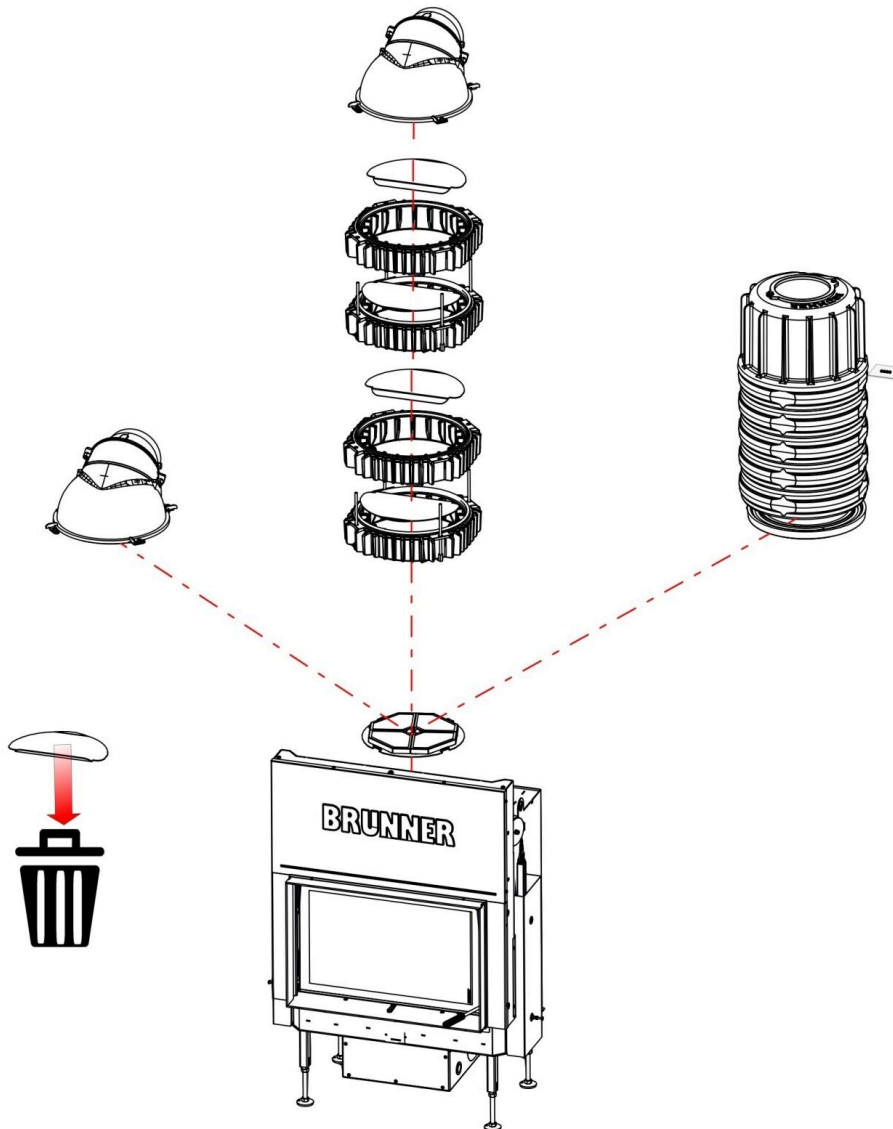

Mounting
catalytic
converter:
see

“ Fitting:
catalytic
converter”

9.2 CONNECTION WITHOUT CATALYTIC CONVERTER

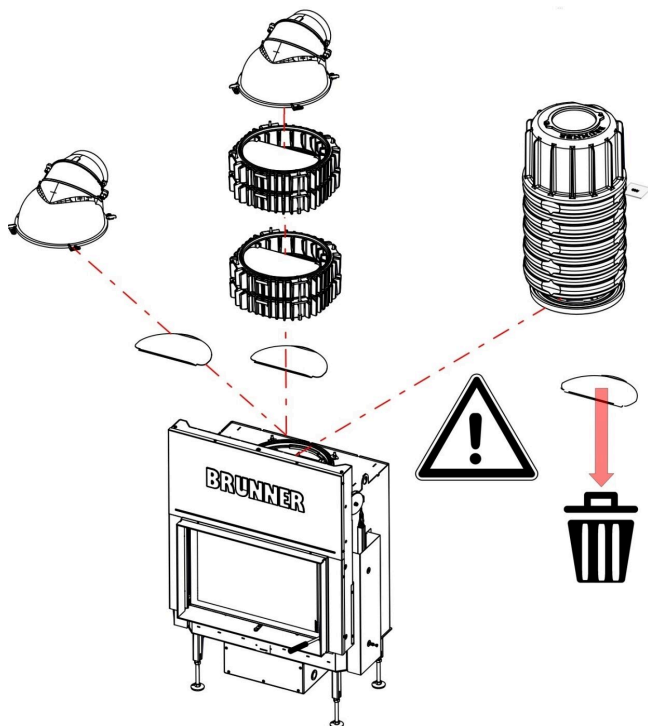

Possible variants of the connection for the outlet of flue gases

Position:
cast iron dome -
deflector plate

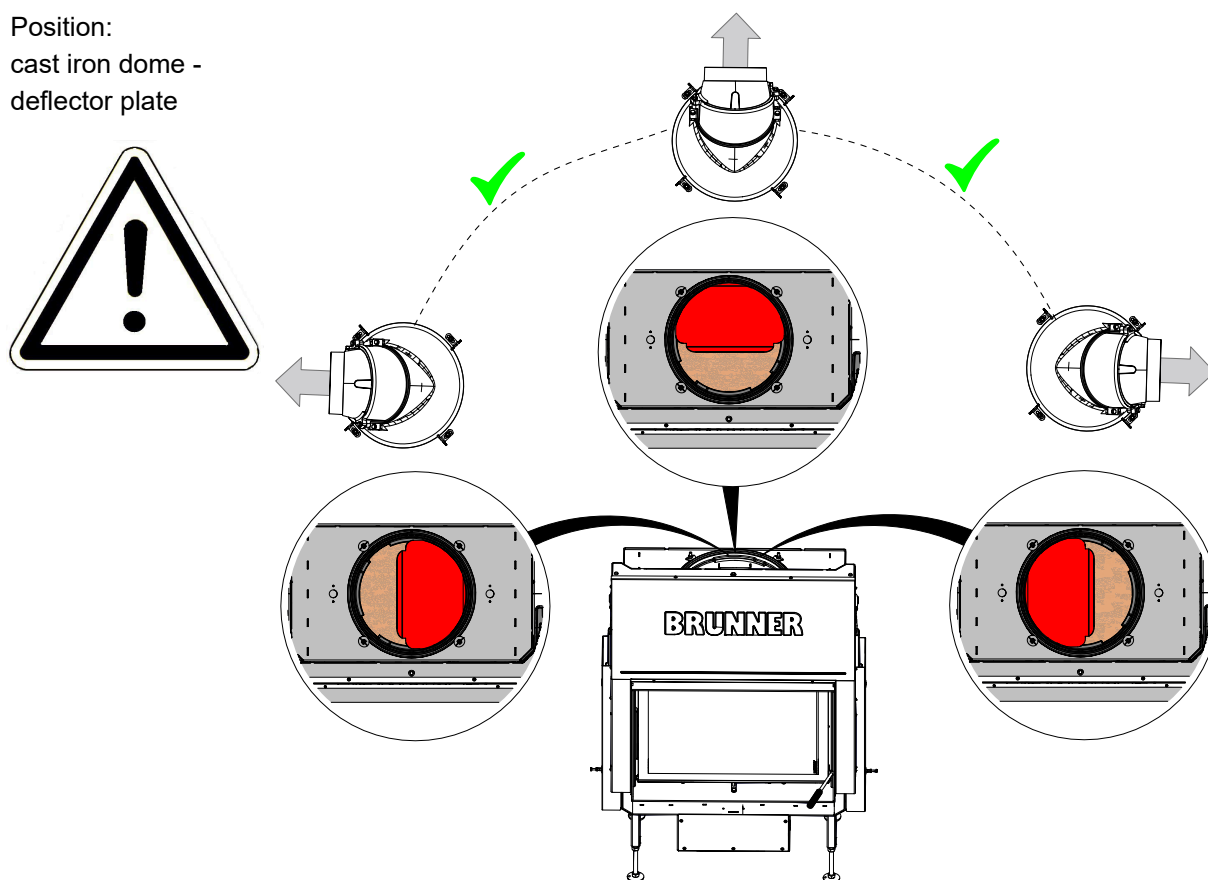

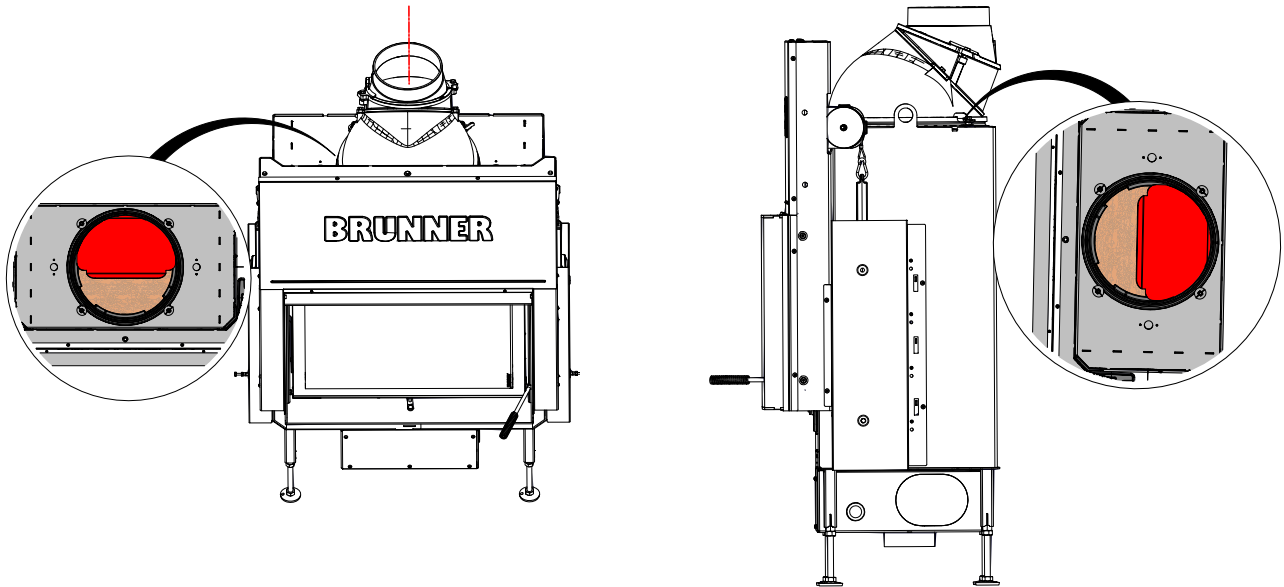
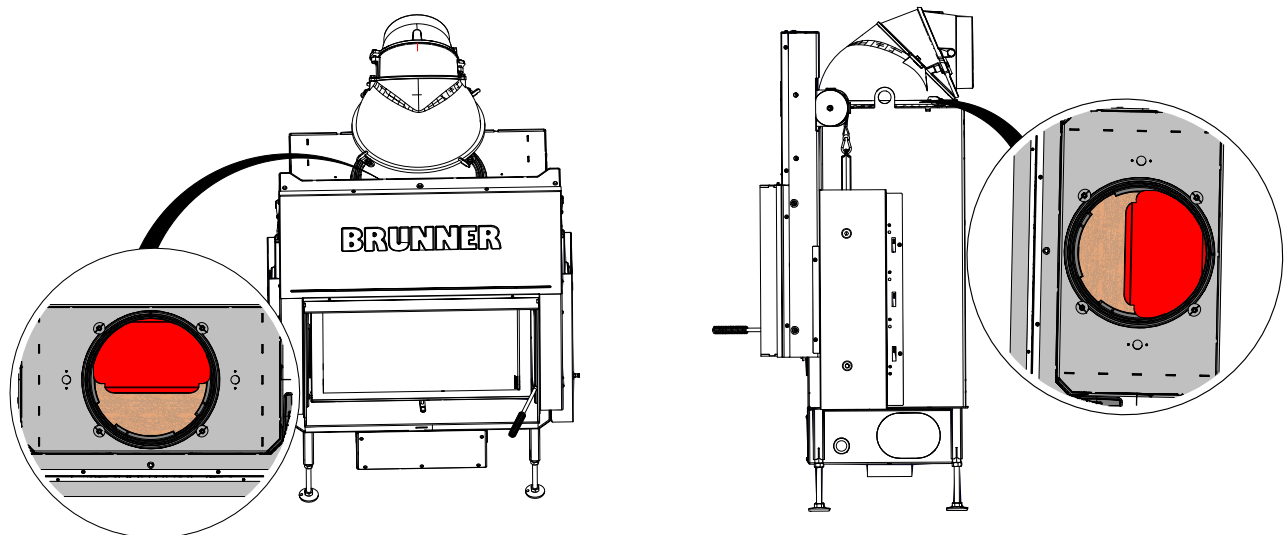
Examples for the position of the deflector plate - Connection variant for exhaust gases**1. Example A: with rotating cast iron dome - at rear - vertical****2. Example B: with rotating cast iron dome - at rear - horizontal**

Example C: with rotating cast iron dome - left side - vertical or horizontal

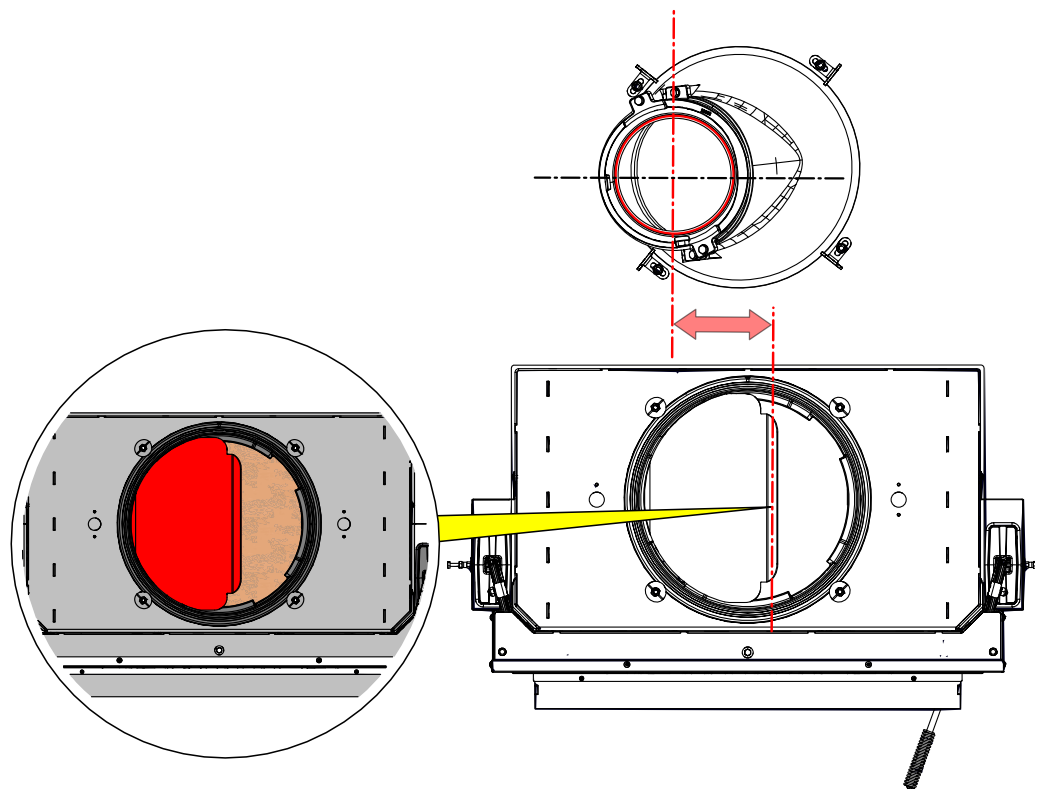
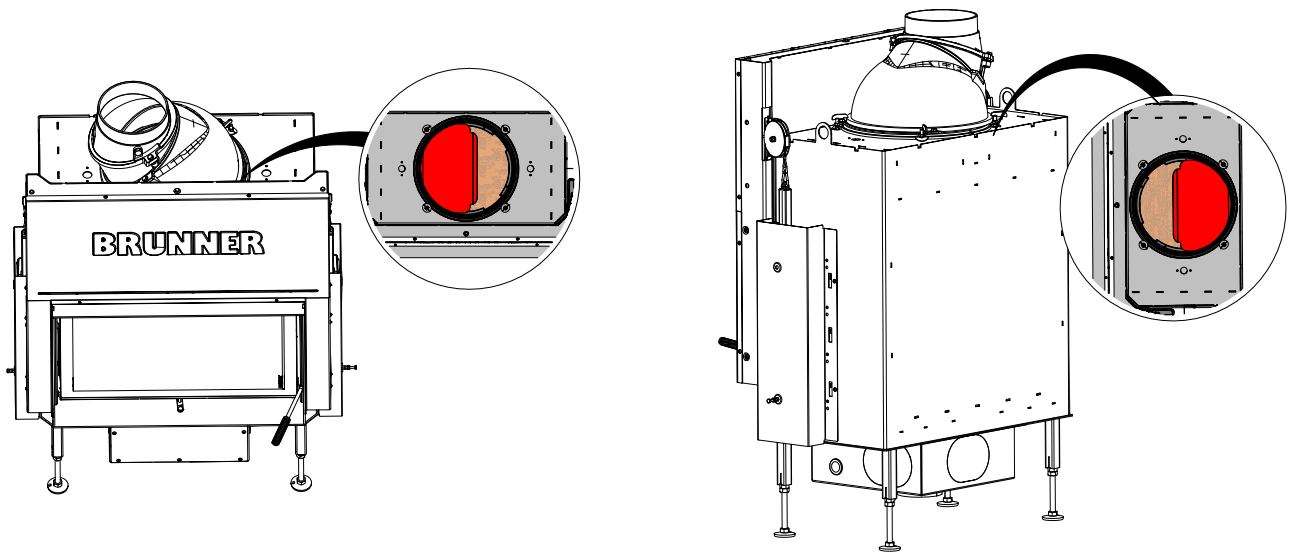

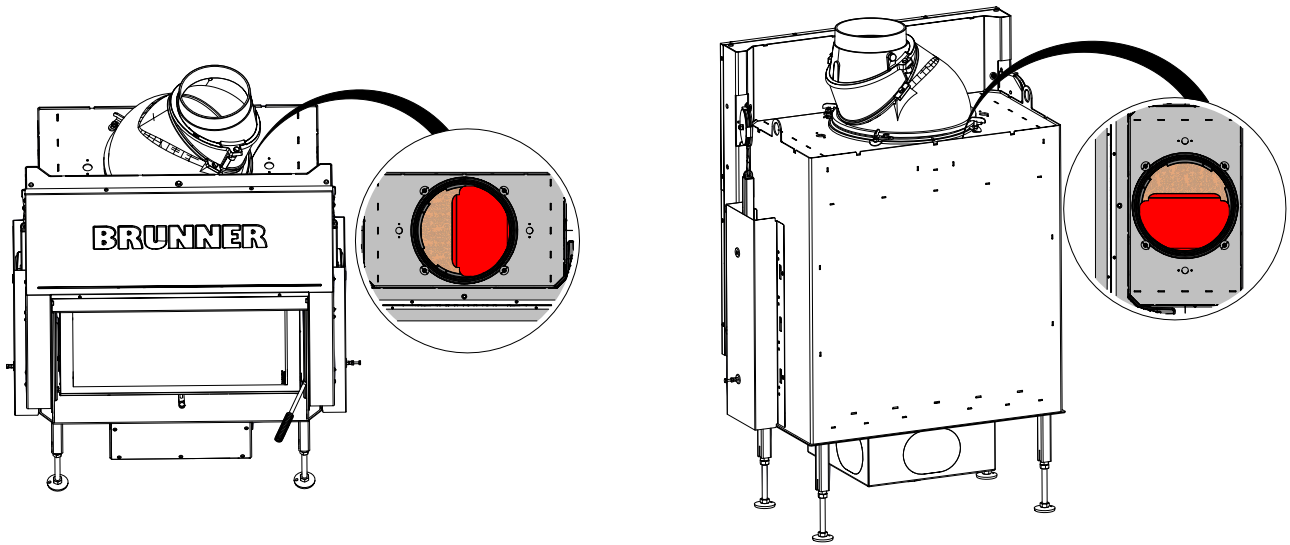
Example D: with rotating cast iron dome right side vertical or horizontal

Example E: with rotating cast iron dome with heat exchanger ring - at rear - vertical or horizontal

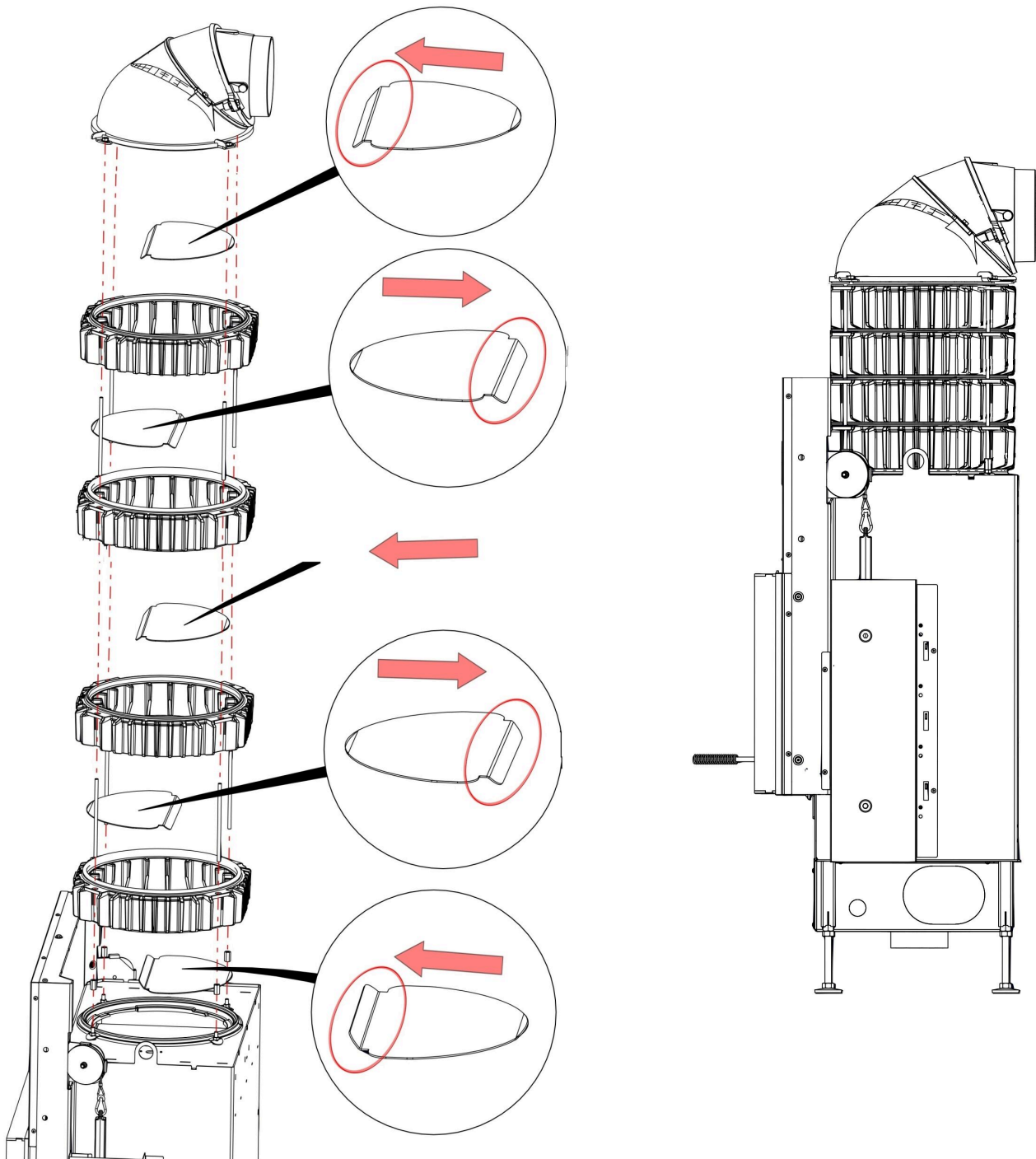

9.3 CAST IRON DOME



vertical outlet

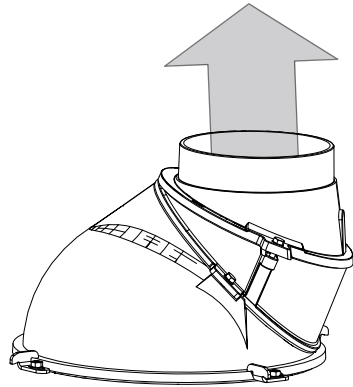

horizontal outlet

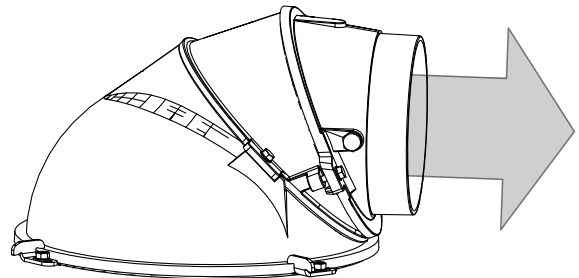

INFO modification: see enclosed sheet - cast iron dome

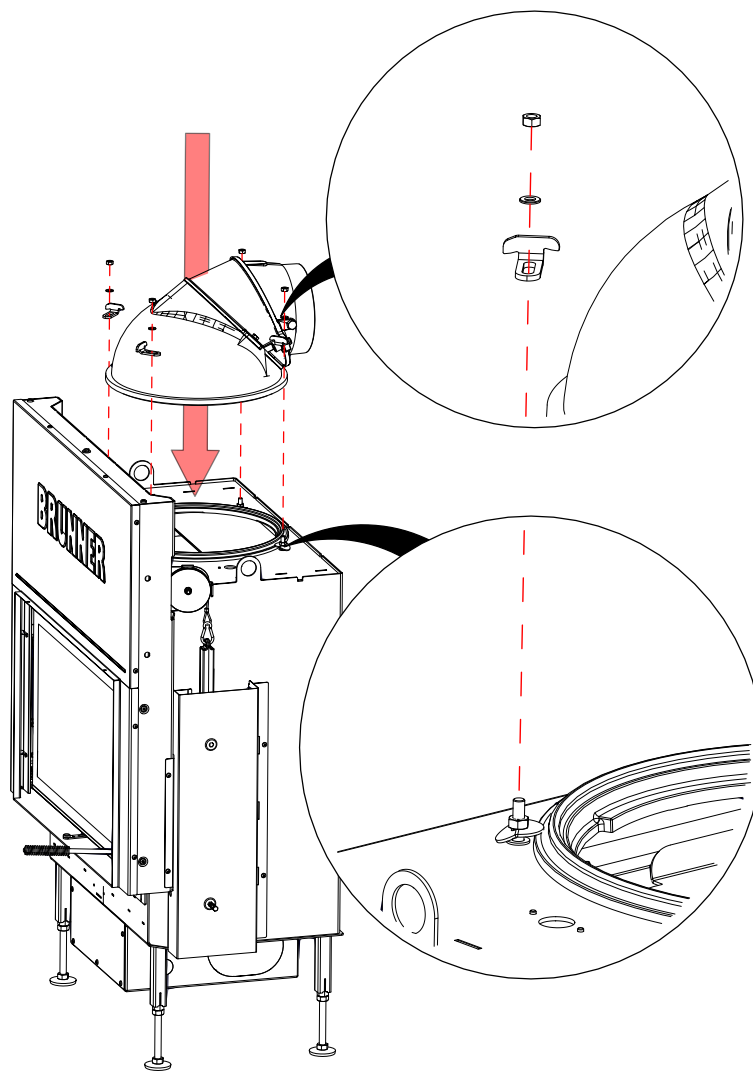

Im. 10: Summarised information

Workflow:

1

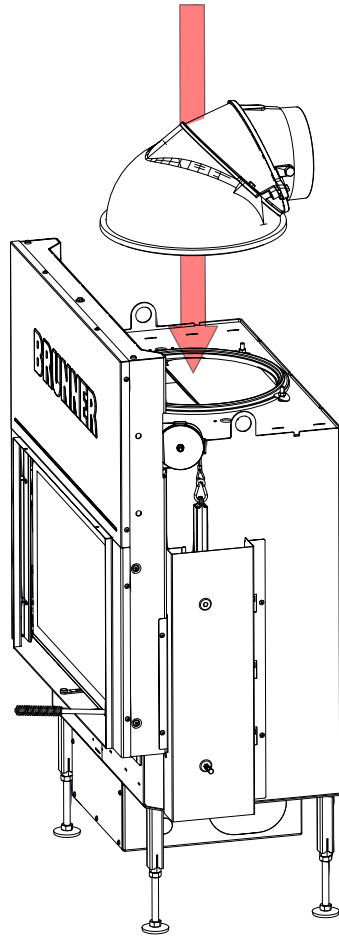

2

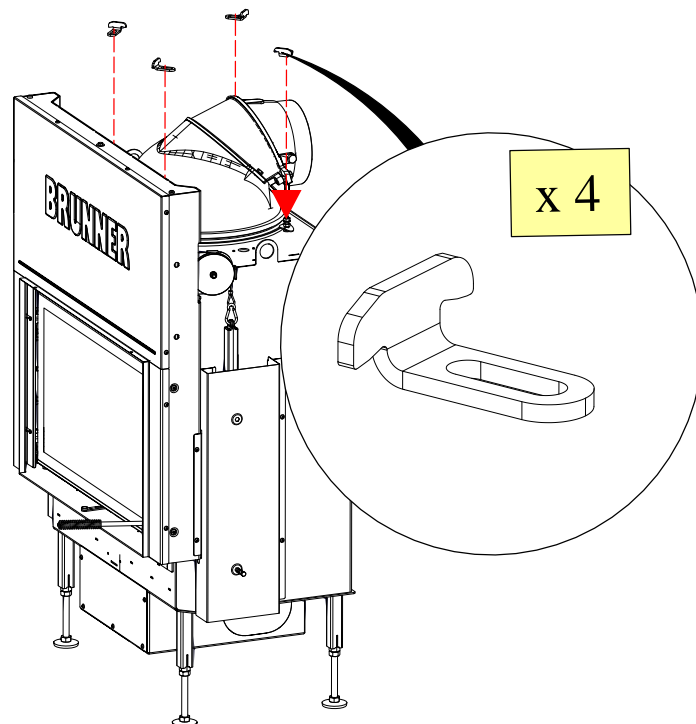

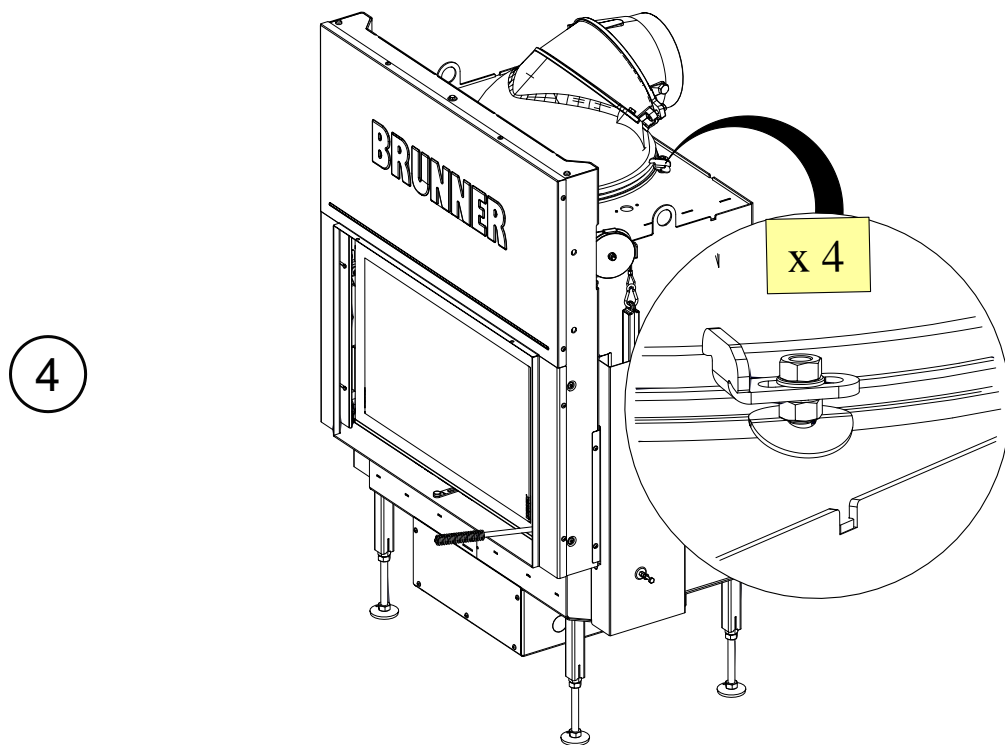
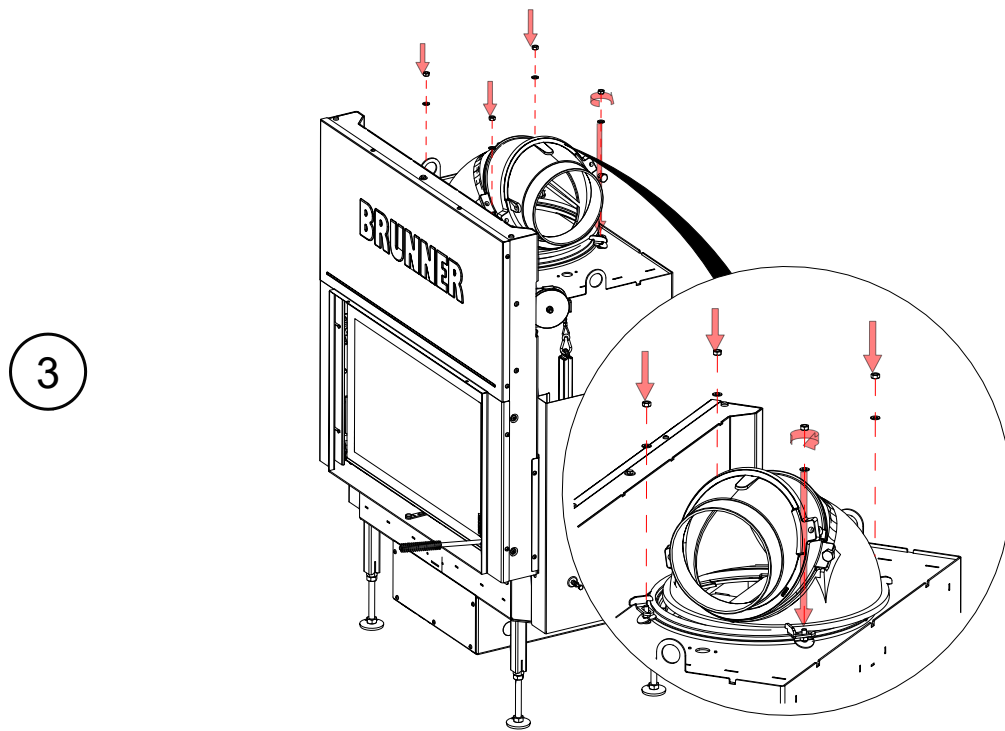

9.4 HEAT EXCHANGER RINGS

Summarised information:

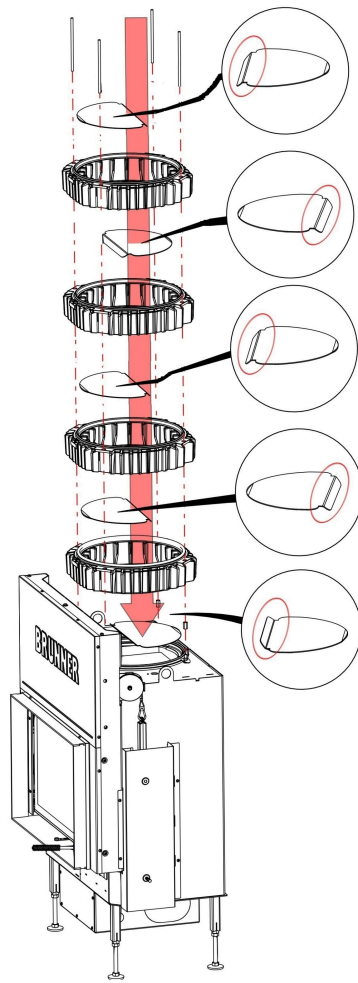

Workflow:

1

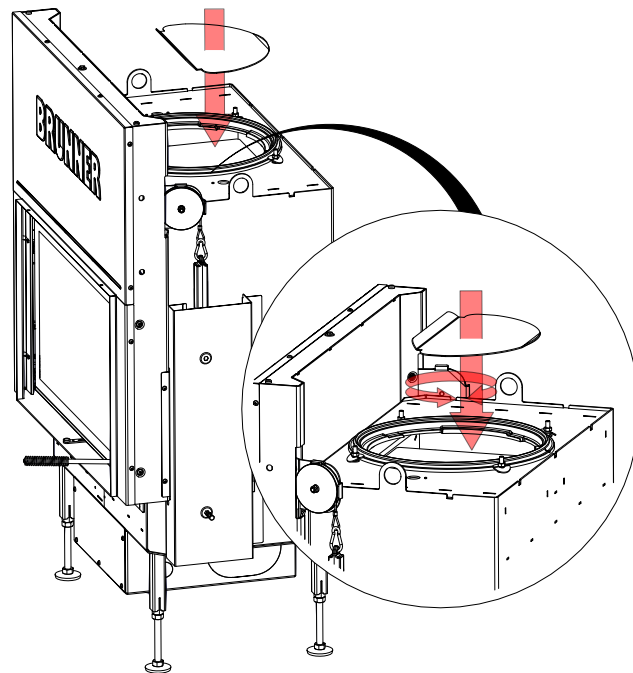

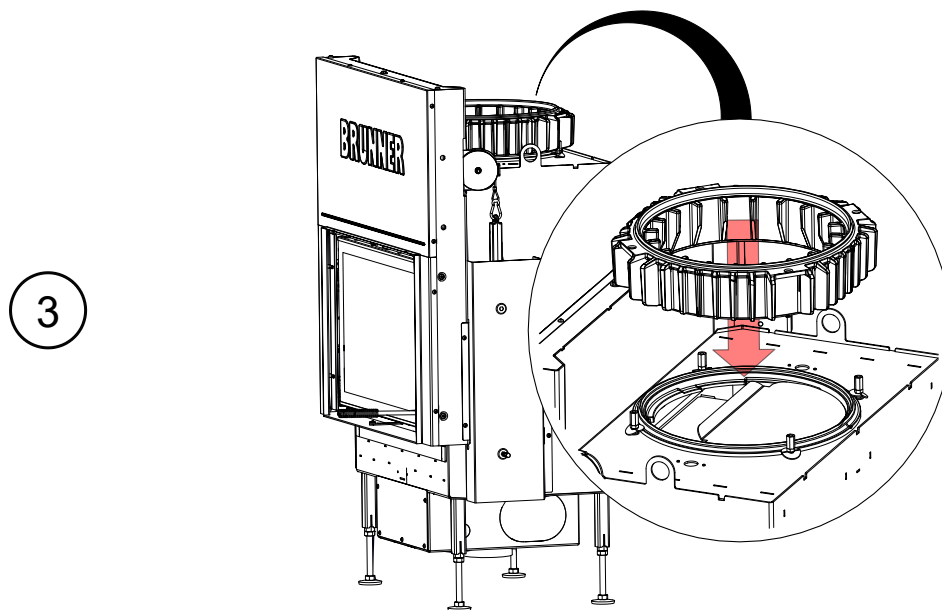
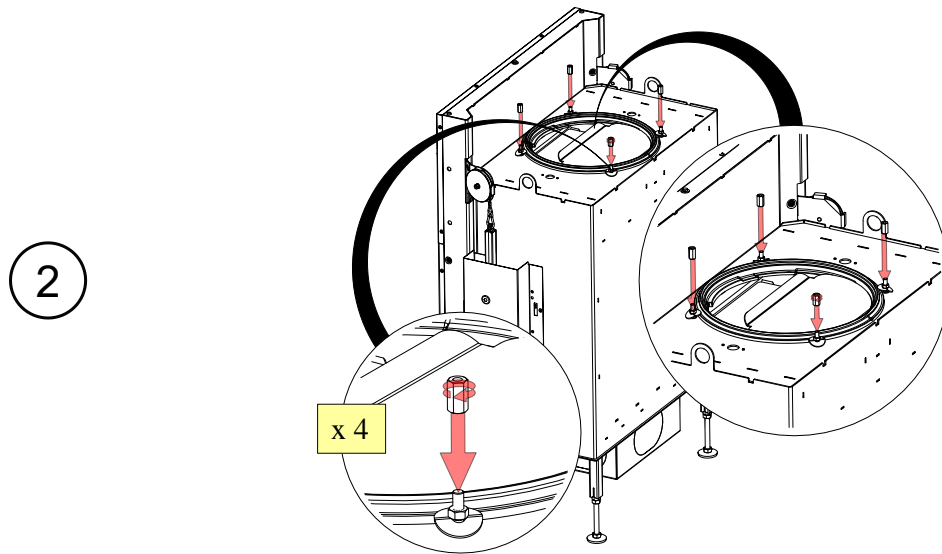

4

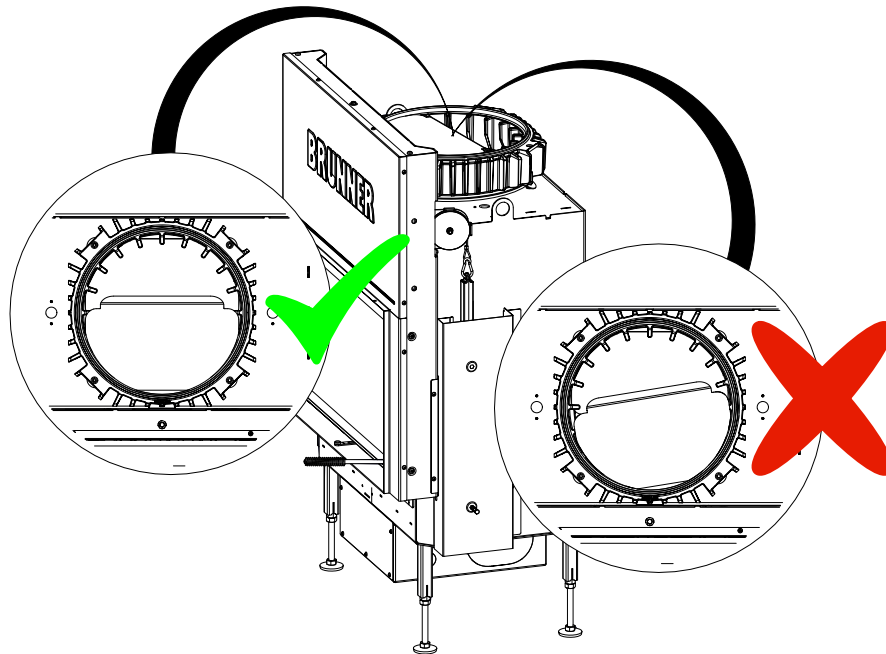
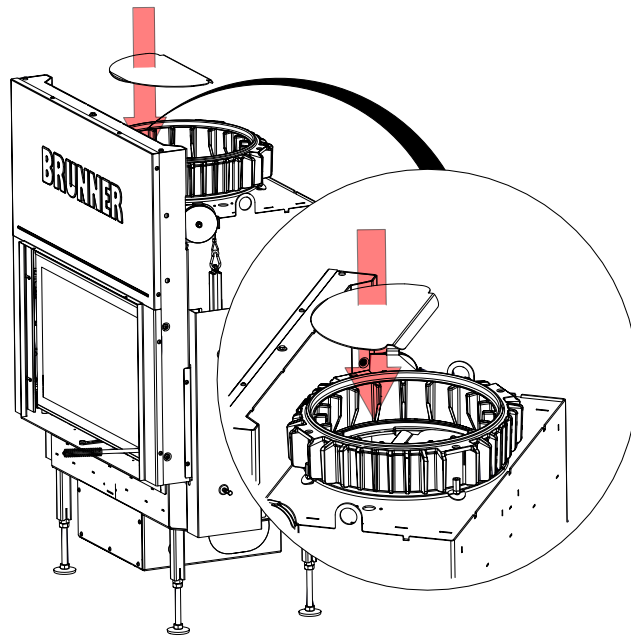

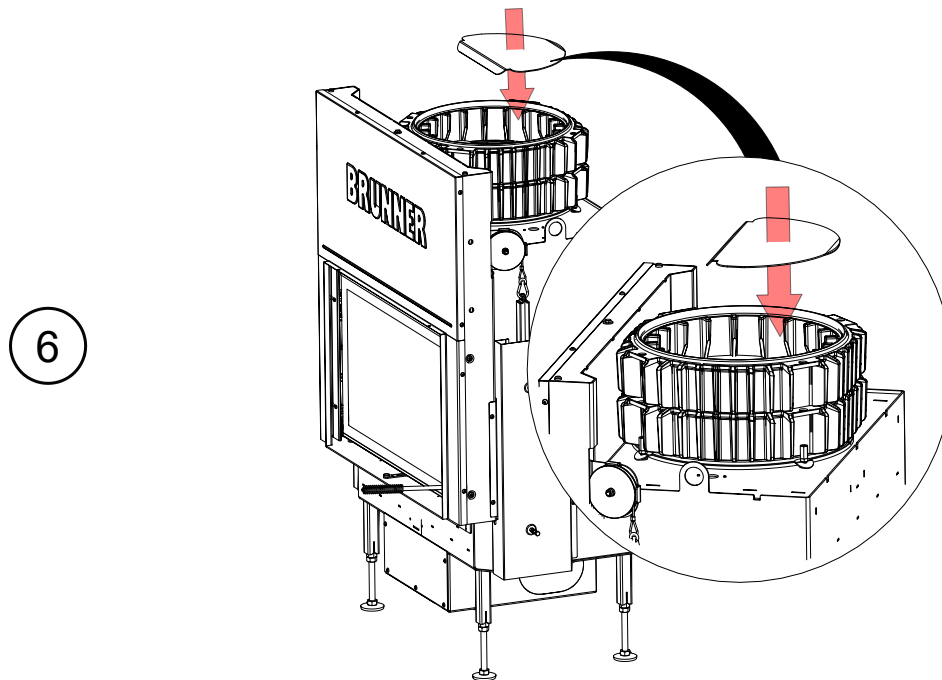
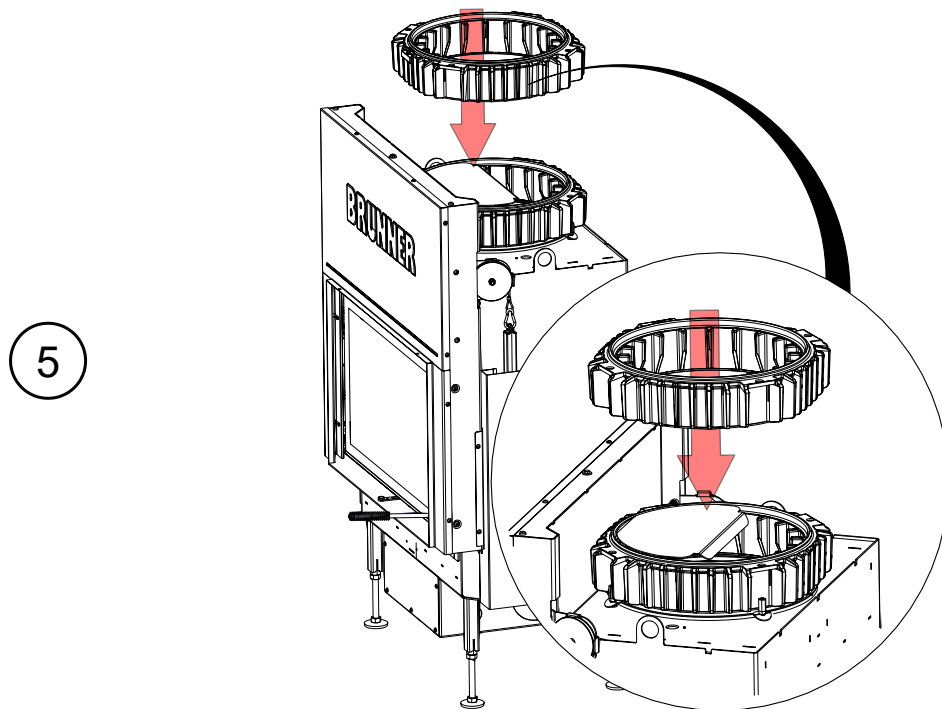

7

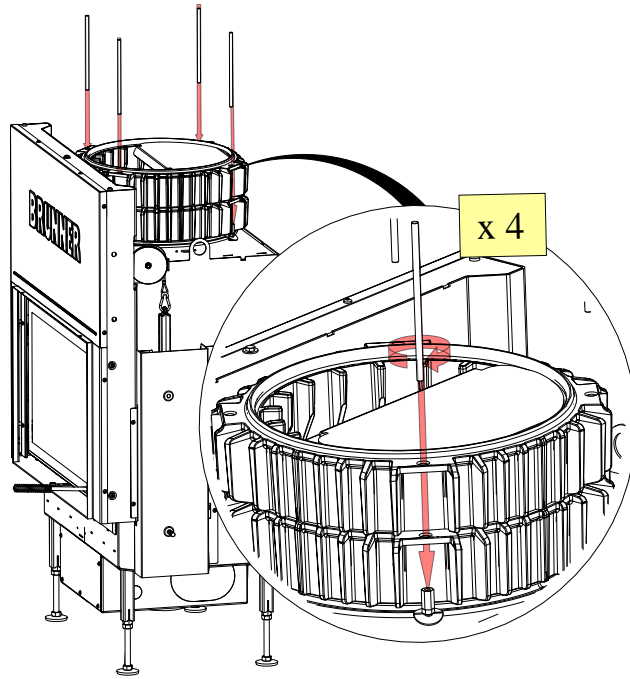

8

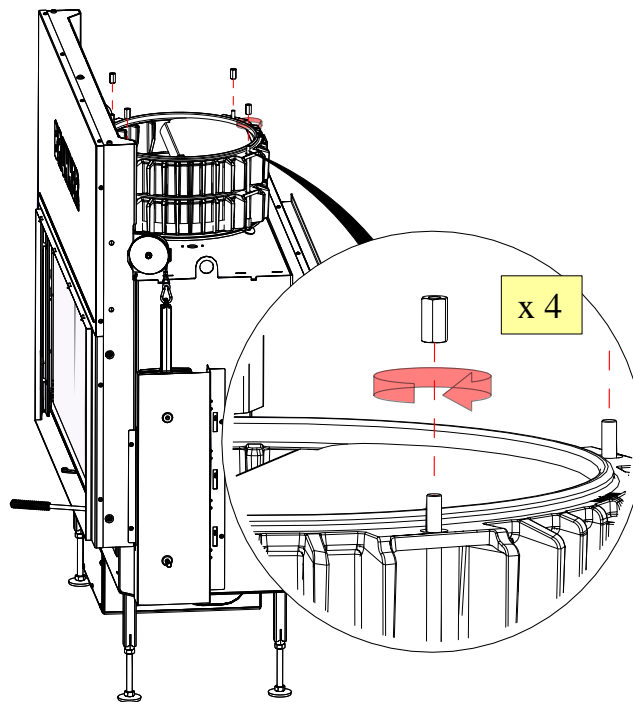

9

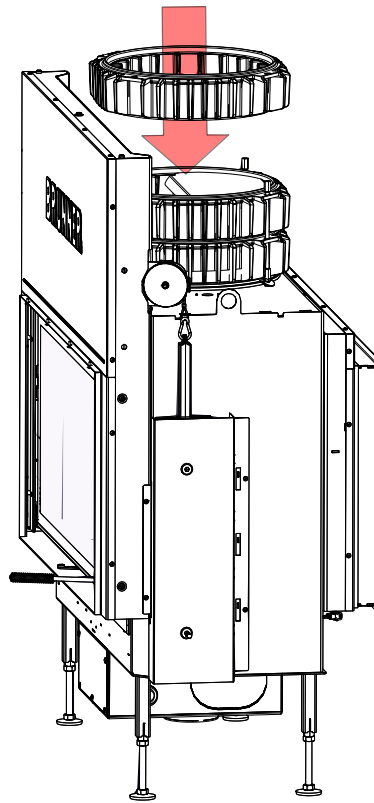

10

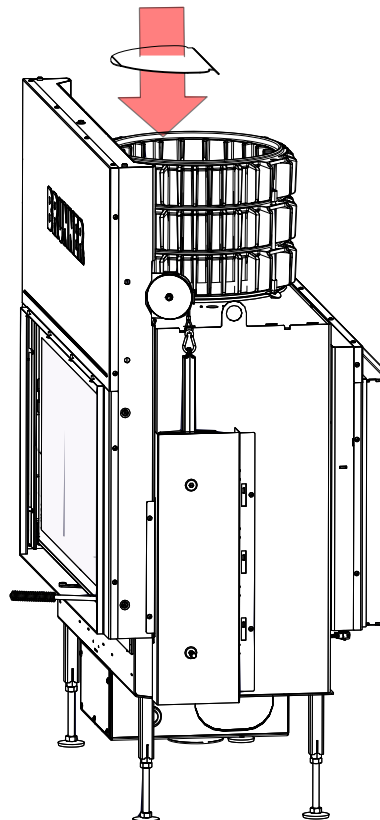

11

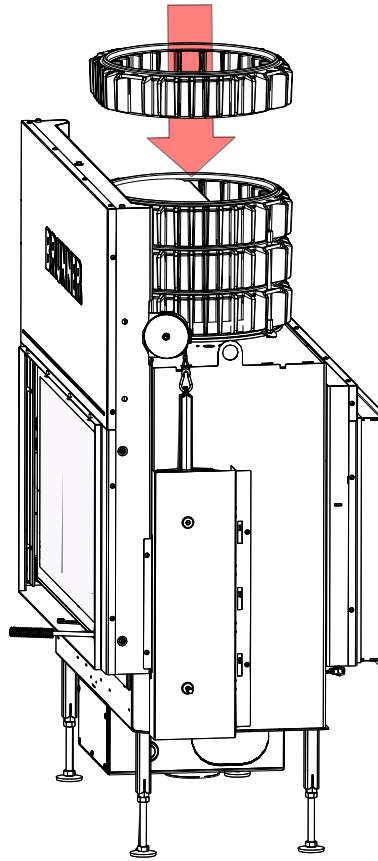

12

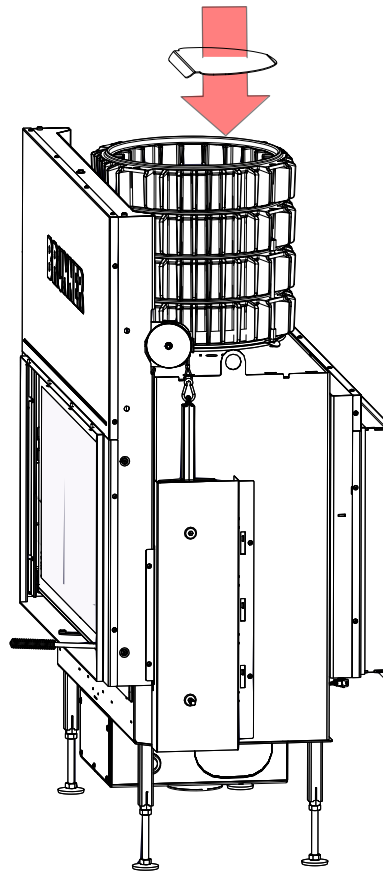

13

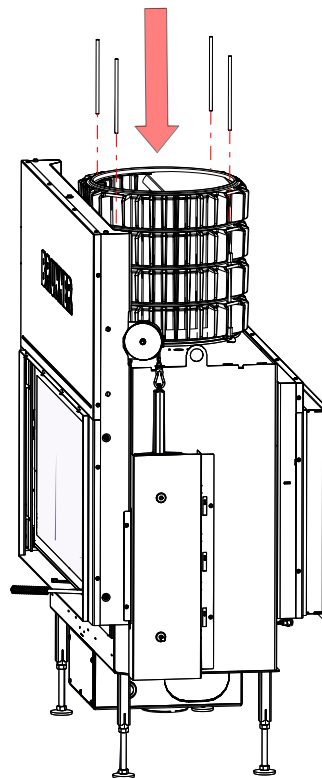

14

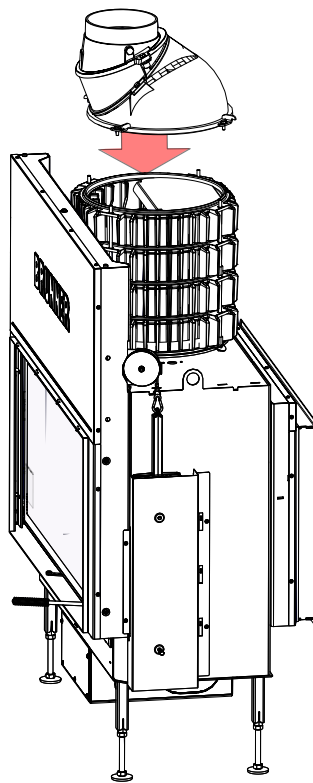

Thereafter: see "Cast iron dome"

9.5 HEAT EXCHANGER MAS

Summarised information:

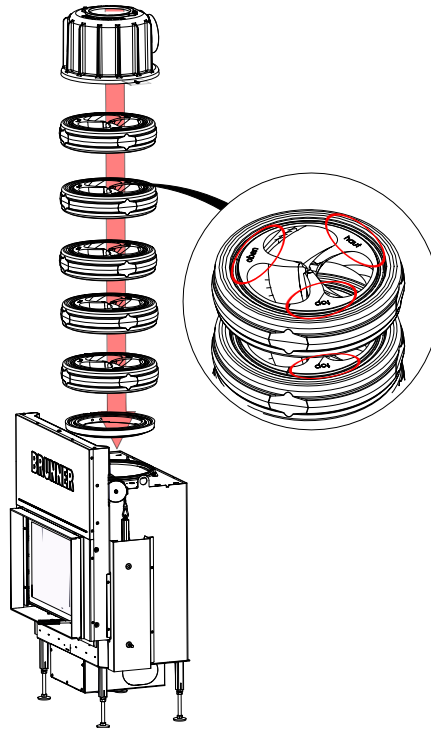

Workflow:

1

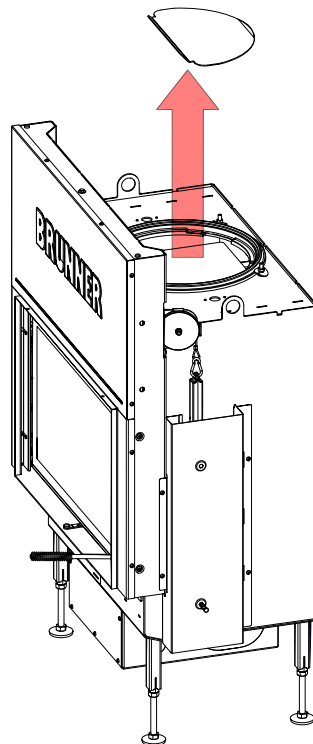

2

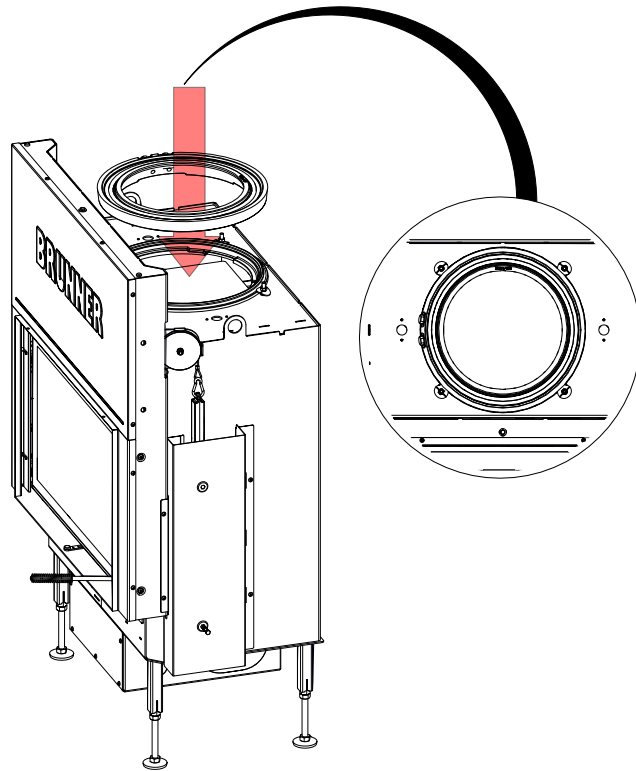

3

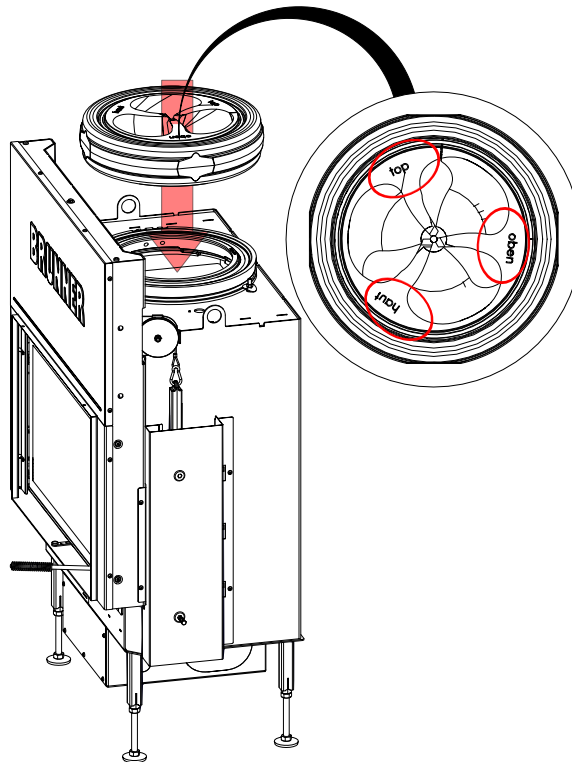

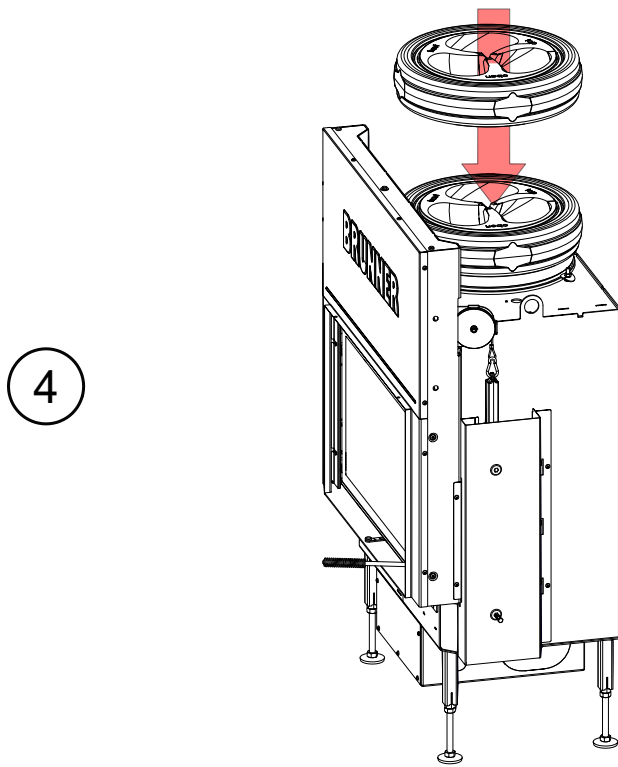

5

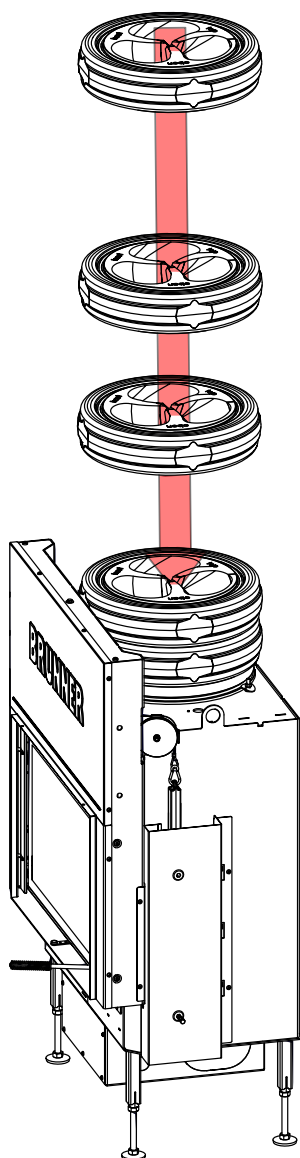

6

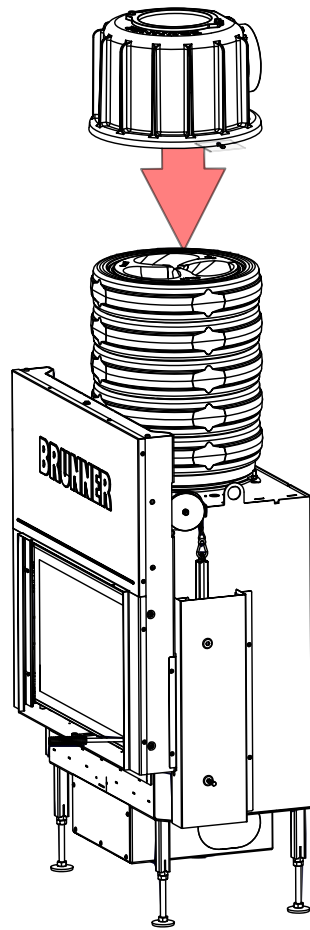

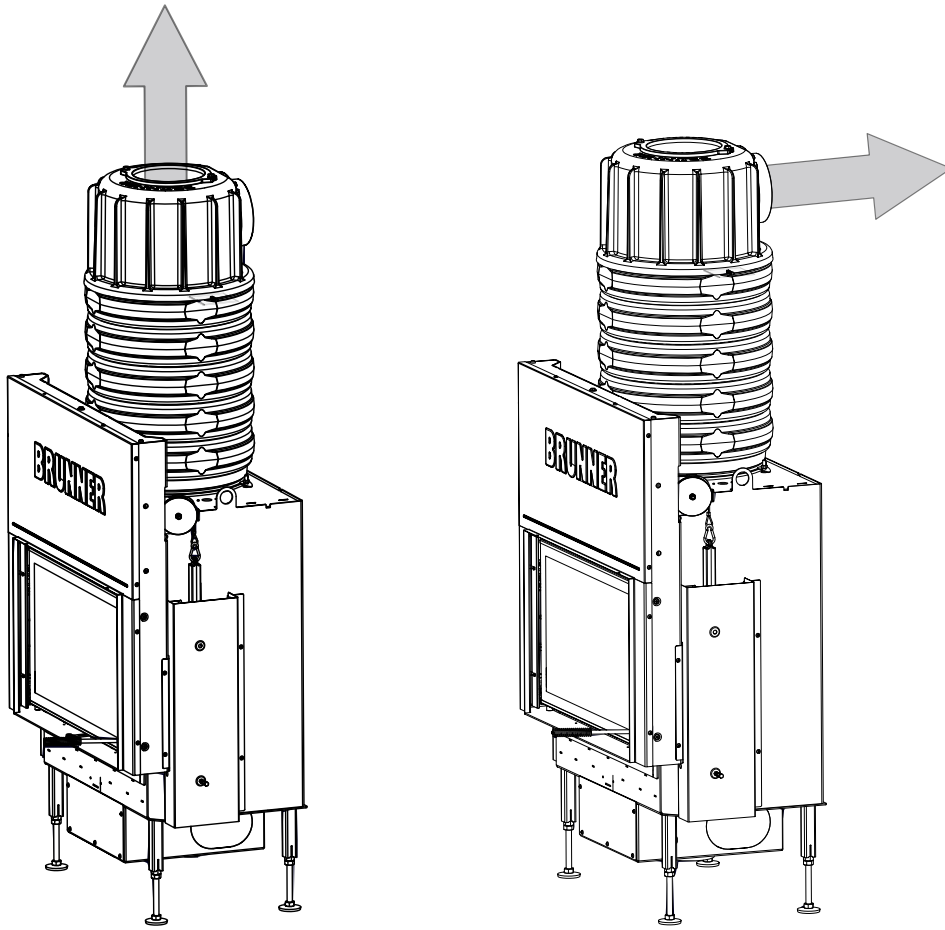

10 FRAME VARIANTS

10.1 MOUNTING FRAME OR DOOR FRAME

Mounting frame or door frame

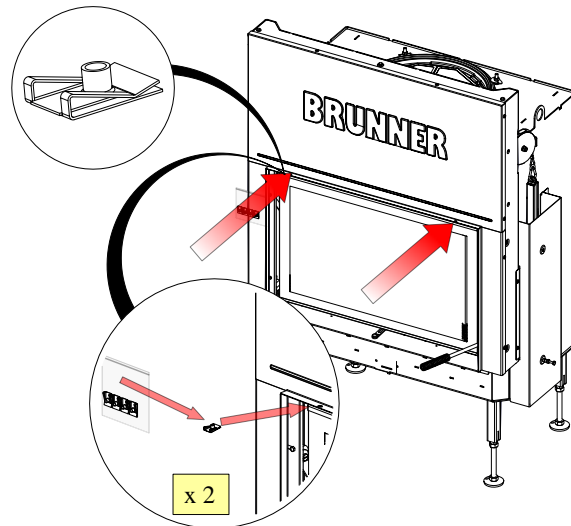

Mounting: mounting frame

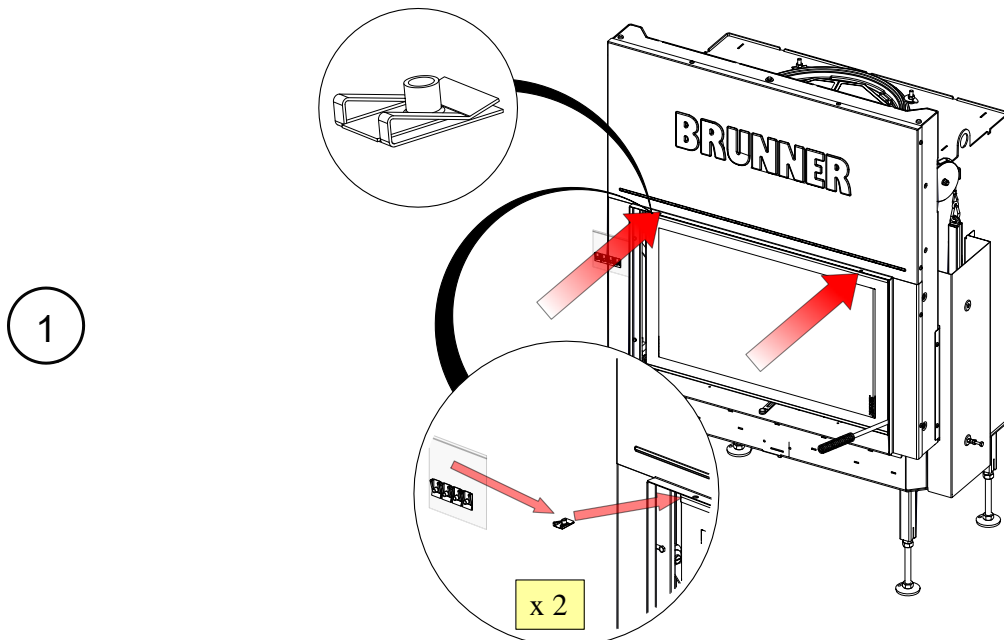

2

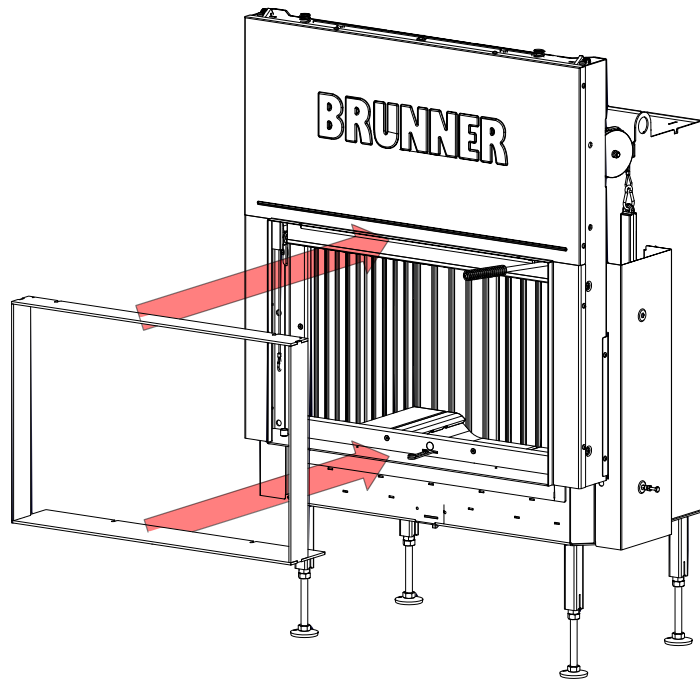

3

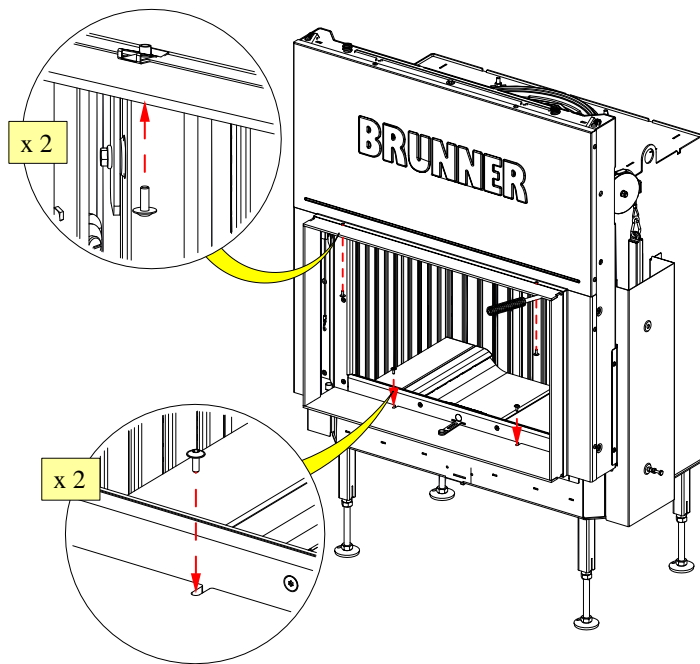

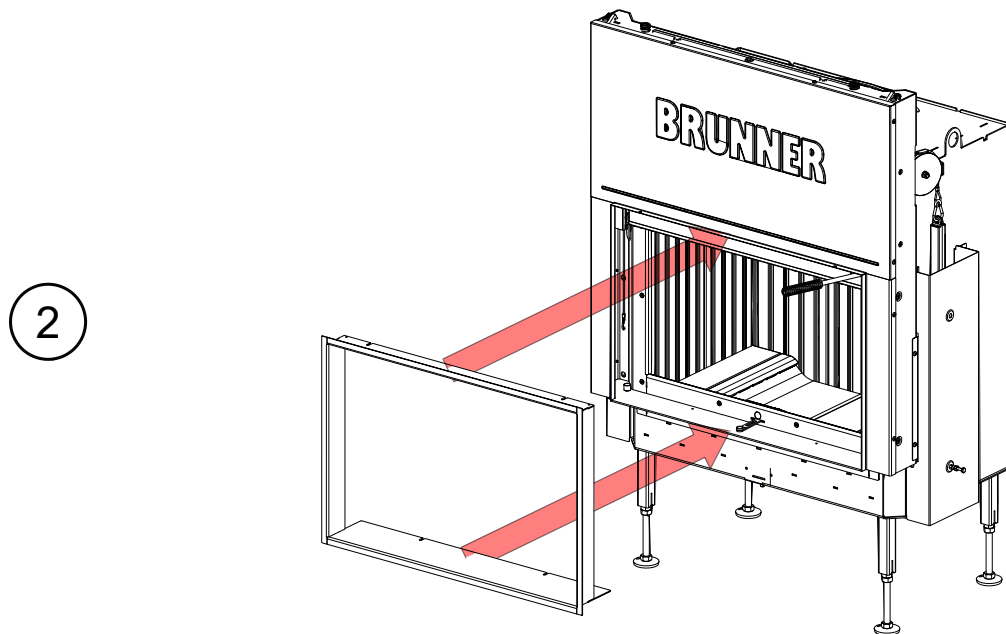
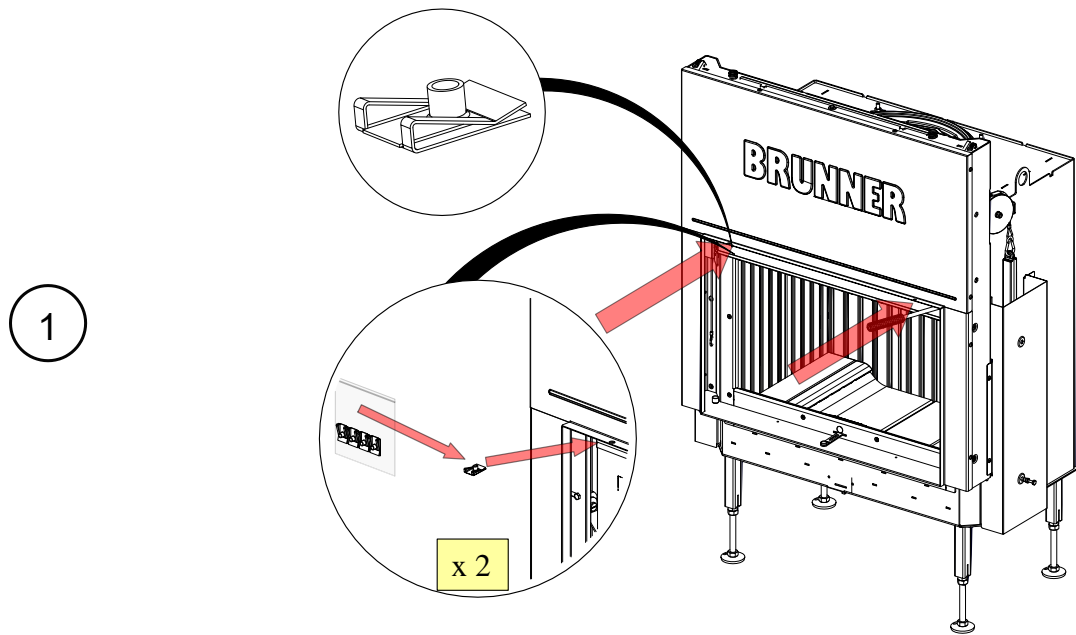
Mounting: door frame

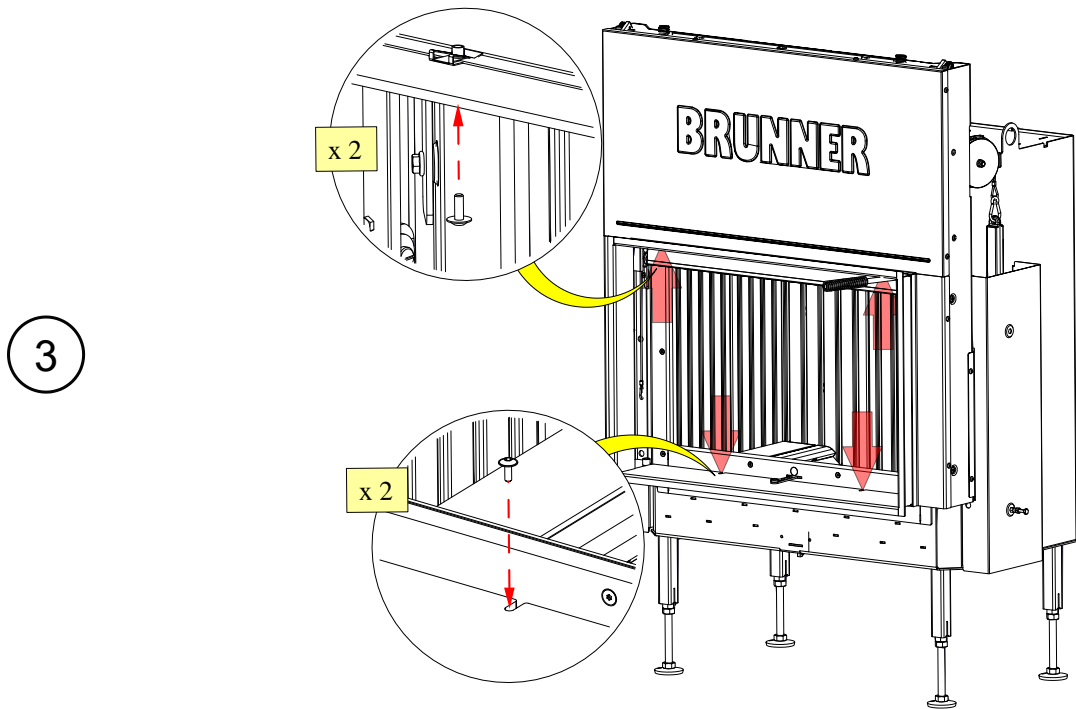

10.2 MOUNTING FRAME OR DOOR FRAME (BKH - SIDE WITH TILTING DOOR)

Summarised information:

Mounting: mounting frame

Mounting: door frame

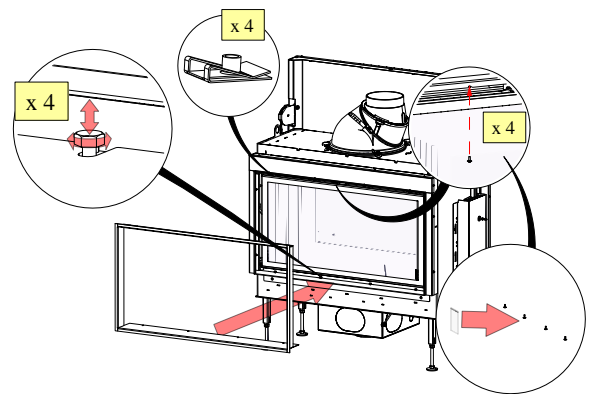
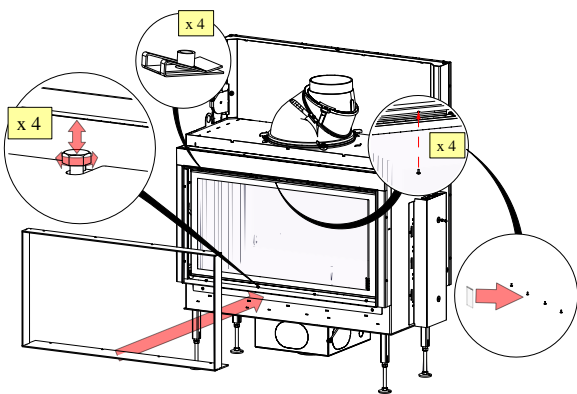

Mounting frame

Workflow:

1

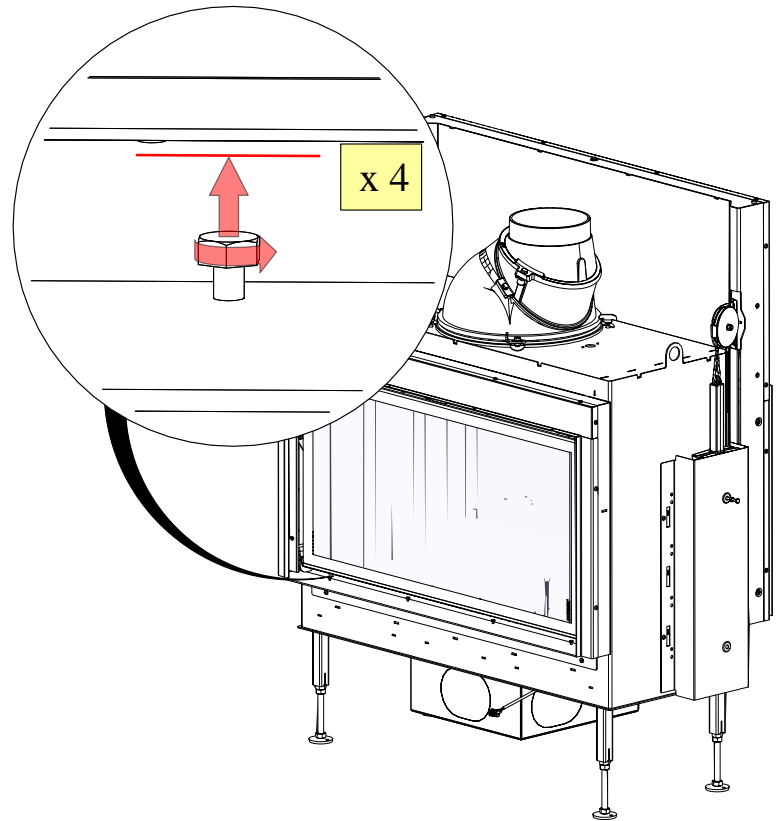

2

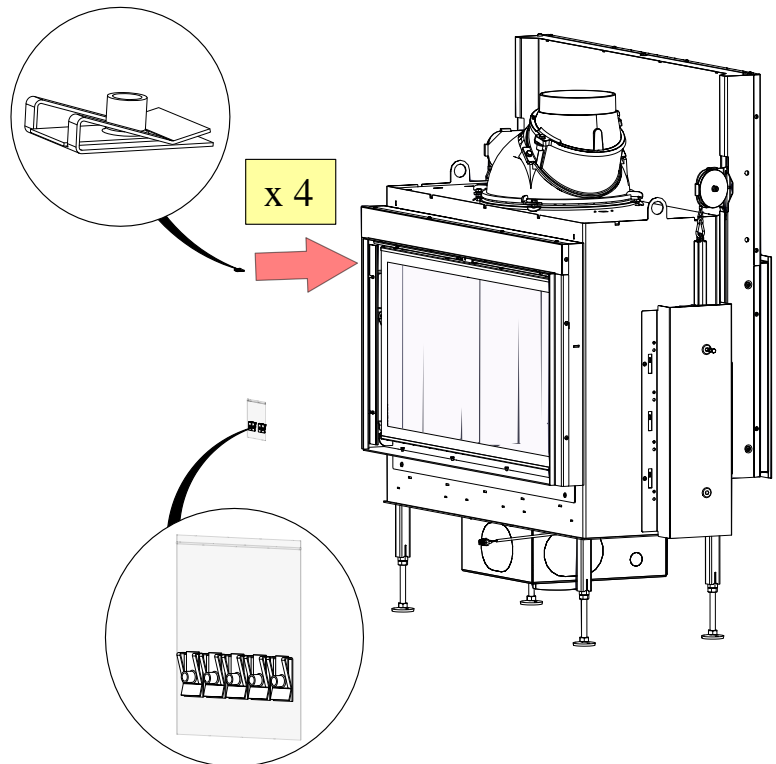

3

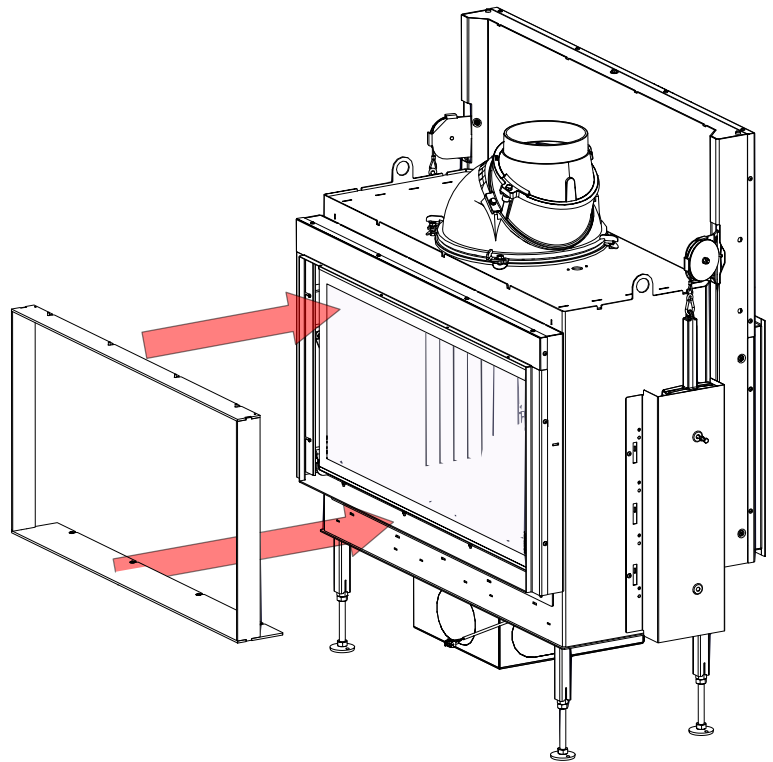

4

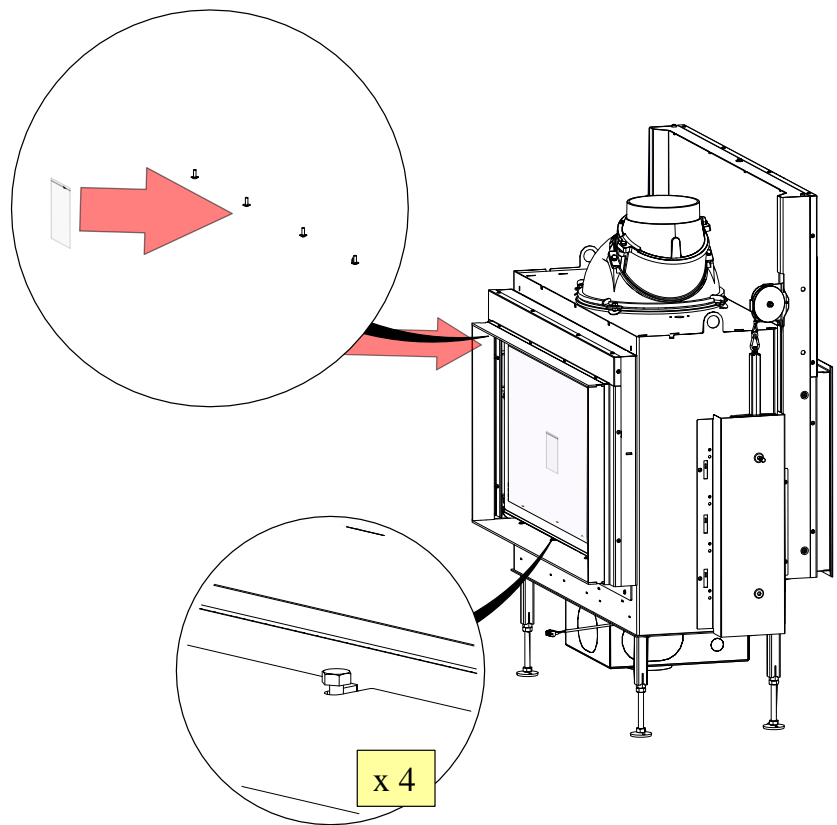

5

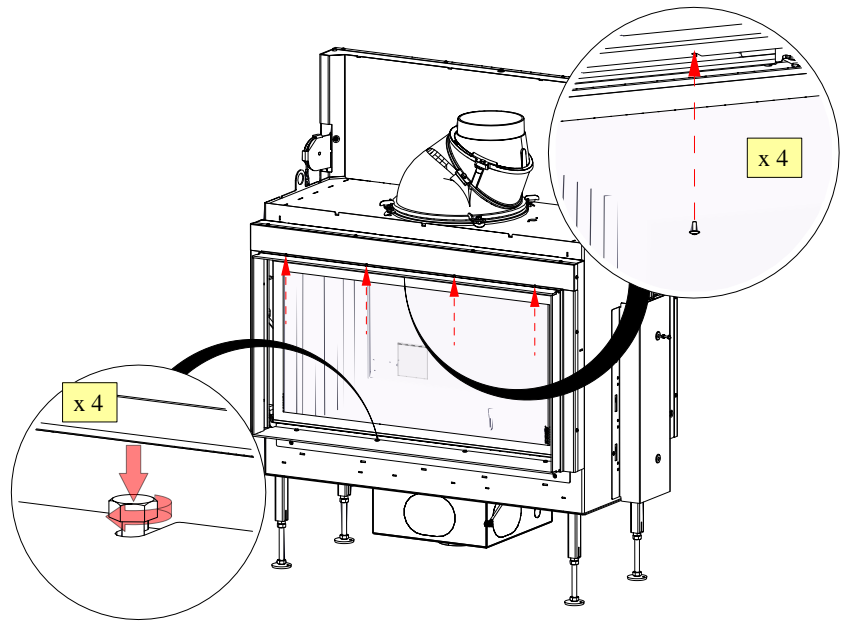

Door frame

Workflow:

1

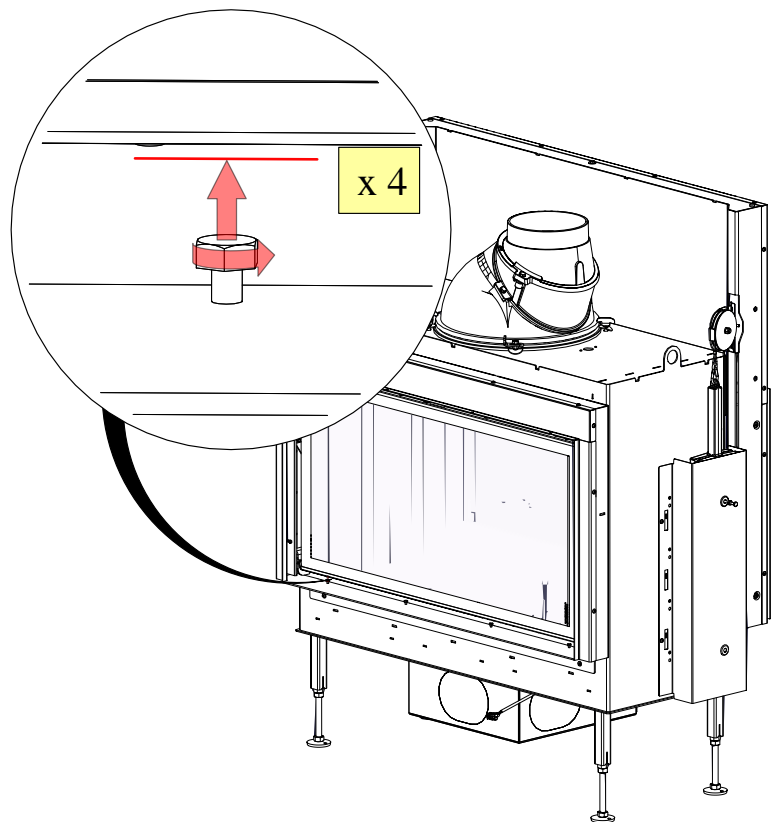

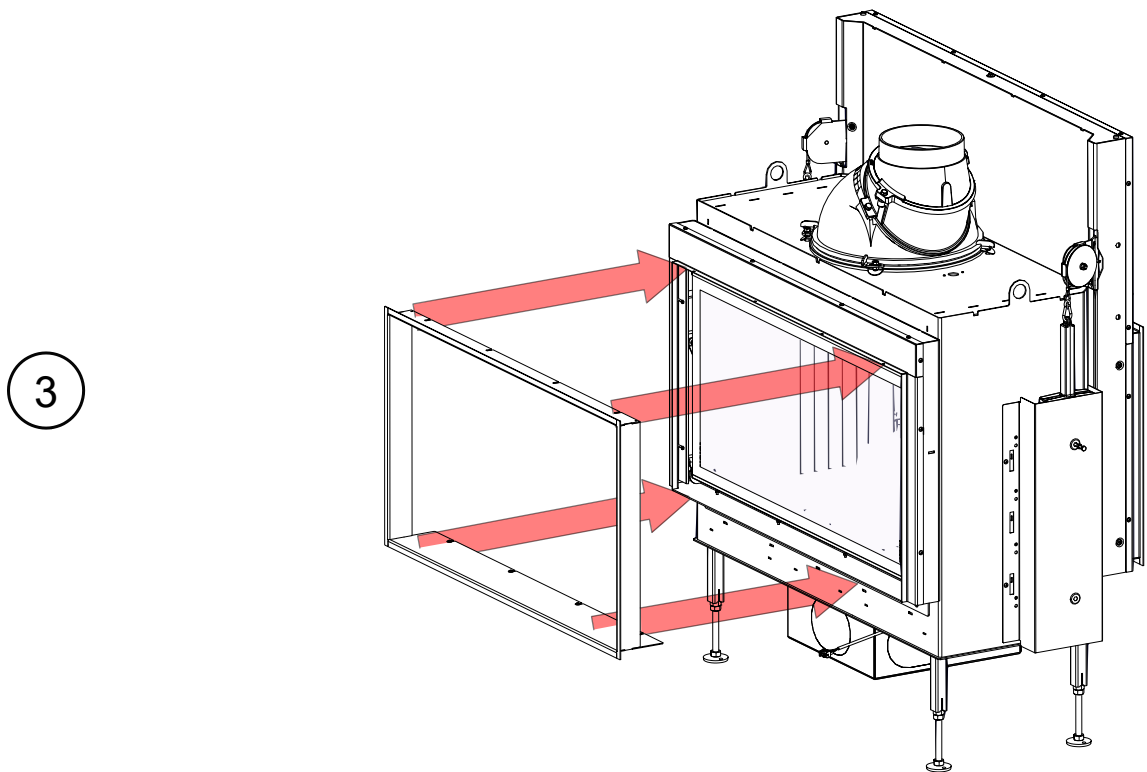
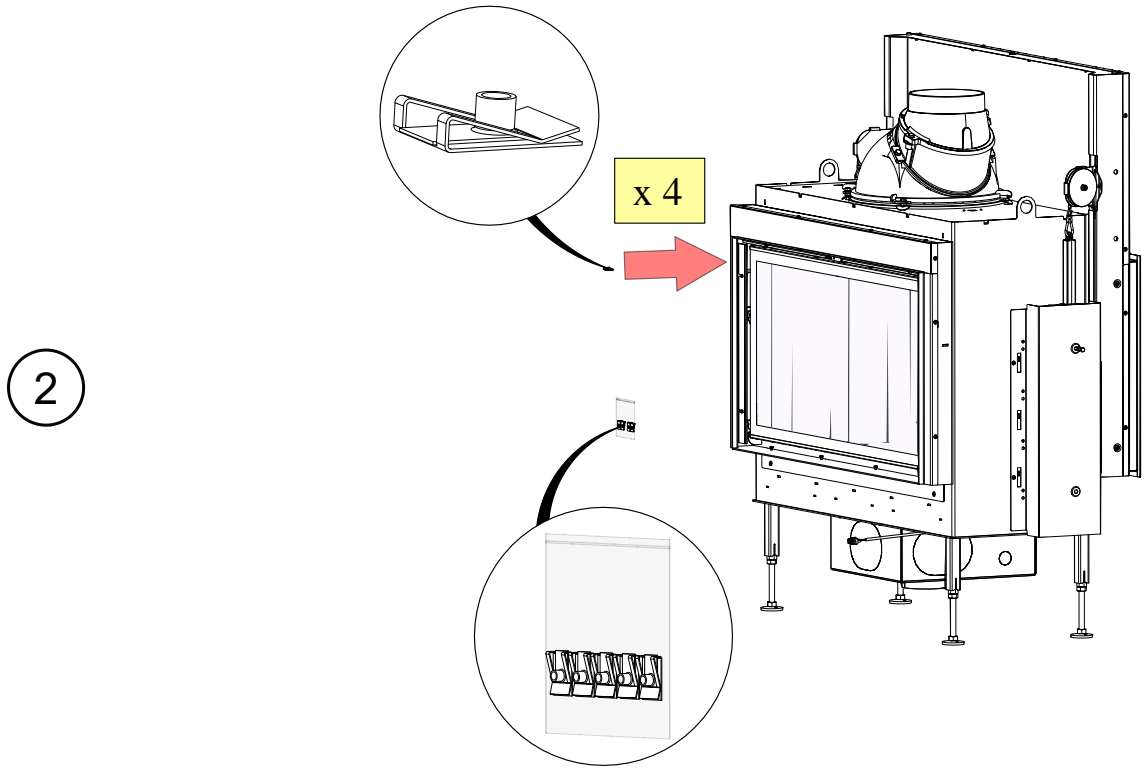

4

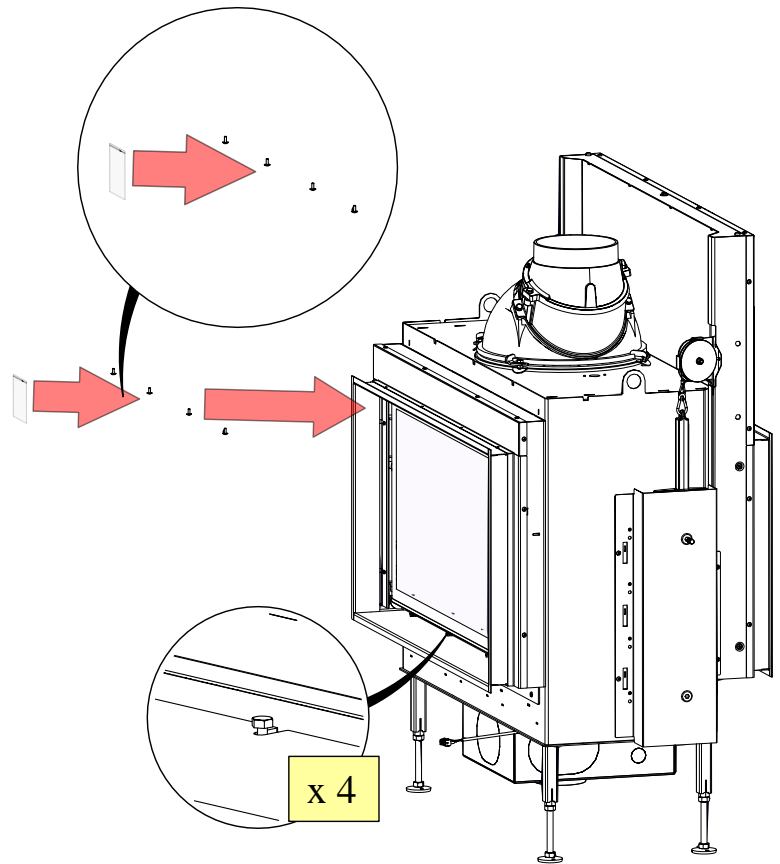

5

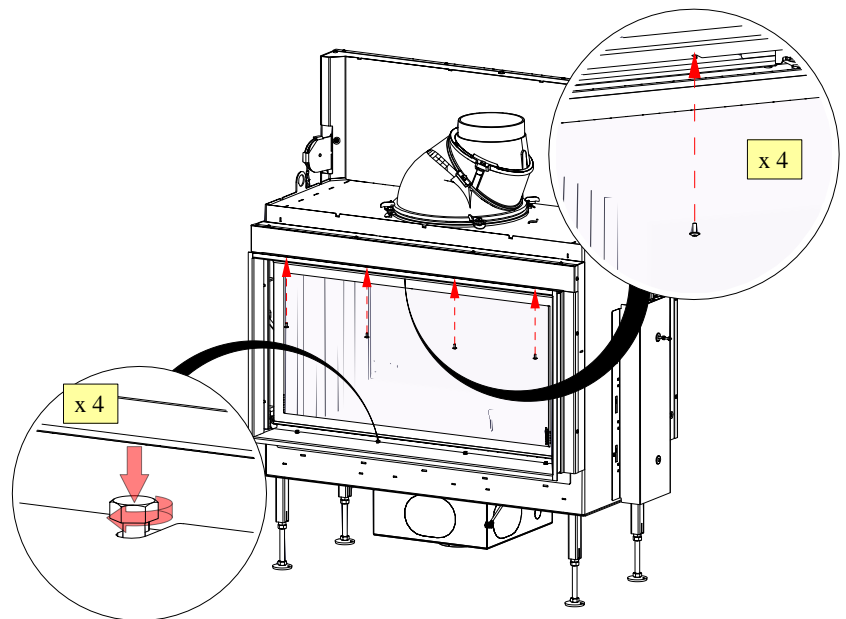

11 CONVERSIONS, SETTINGS

11.1 MODIFICATION - LIFTING DOOR: "NON SELF CLOSING"

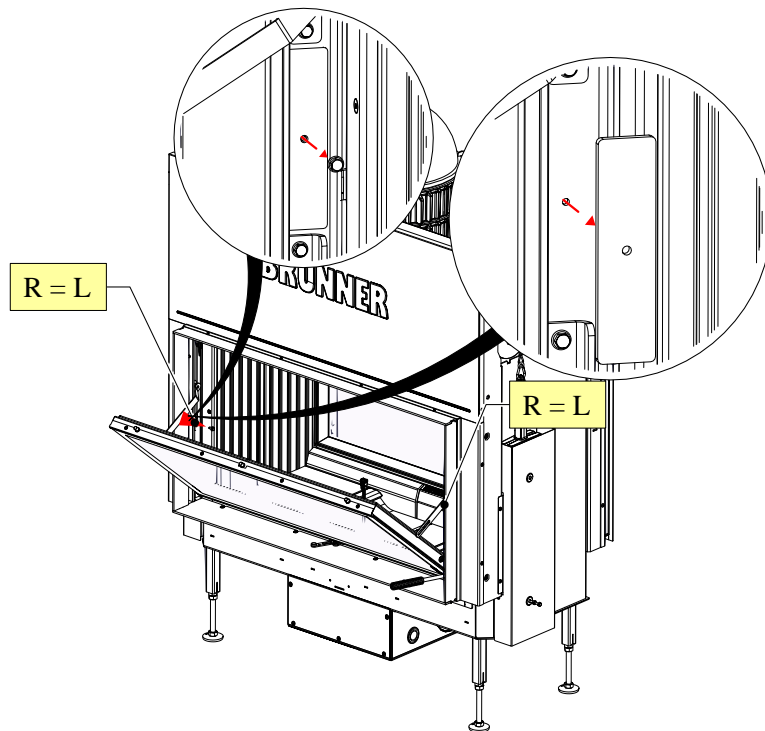

Im. 11: Summarised information

R = right side
L = left side

Workflow:

1

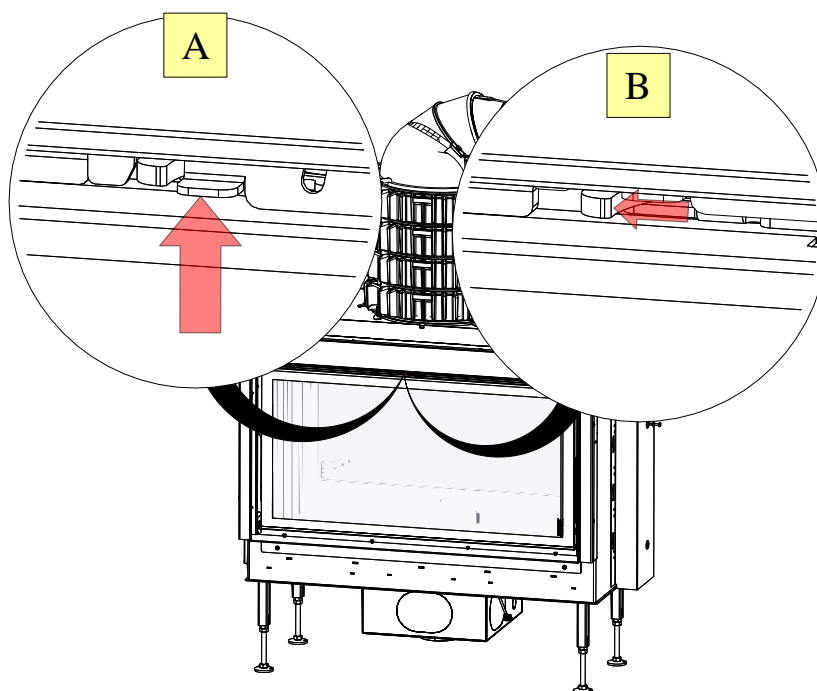

2

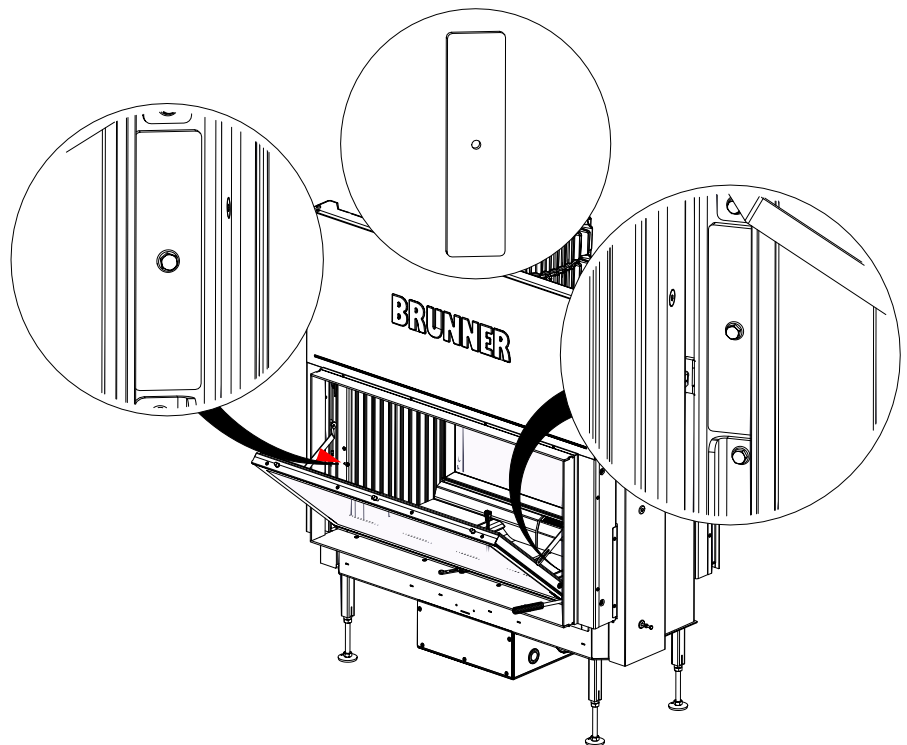
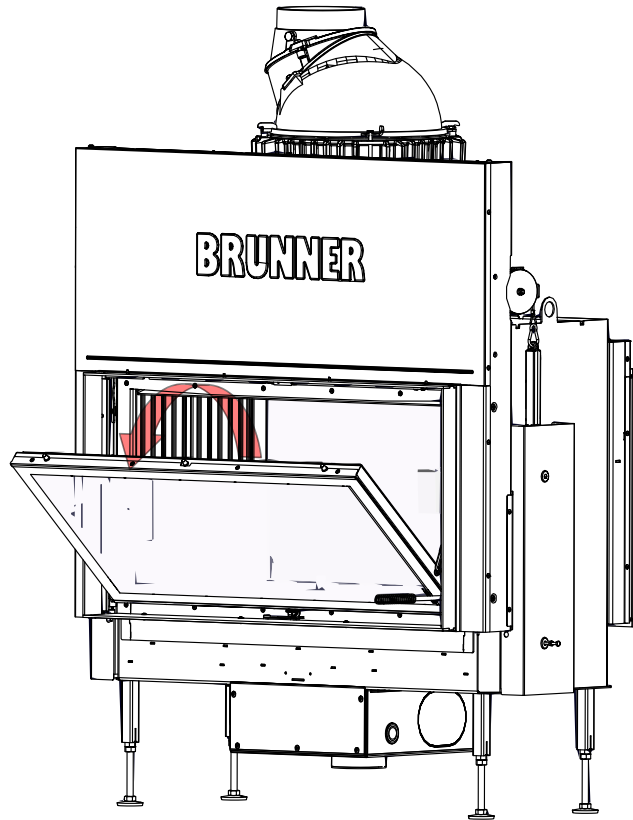

3

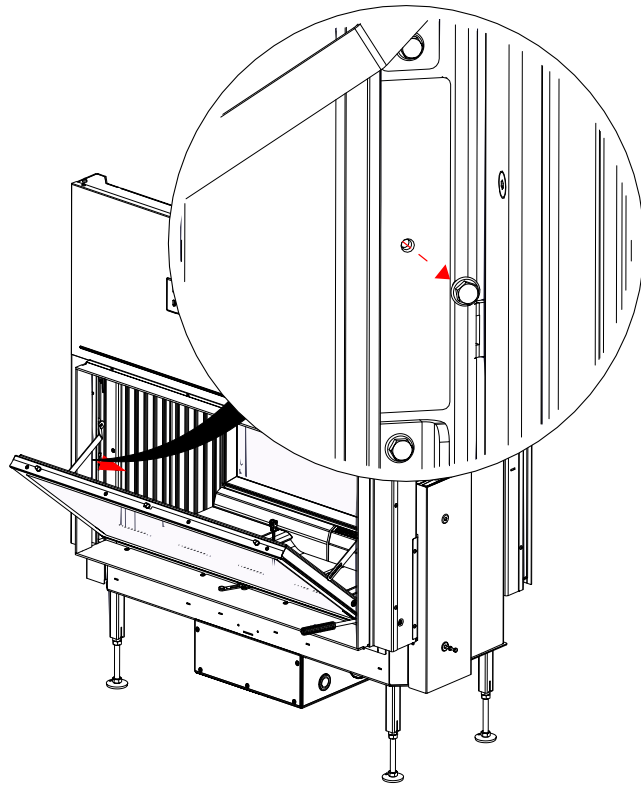

4

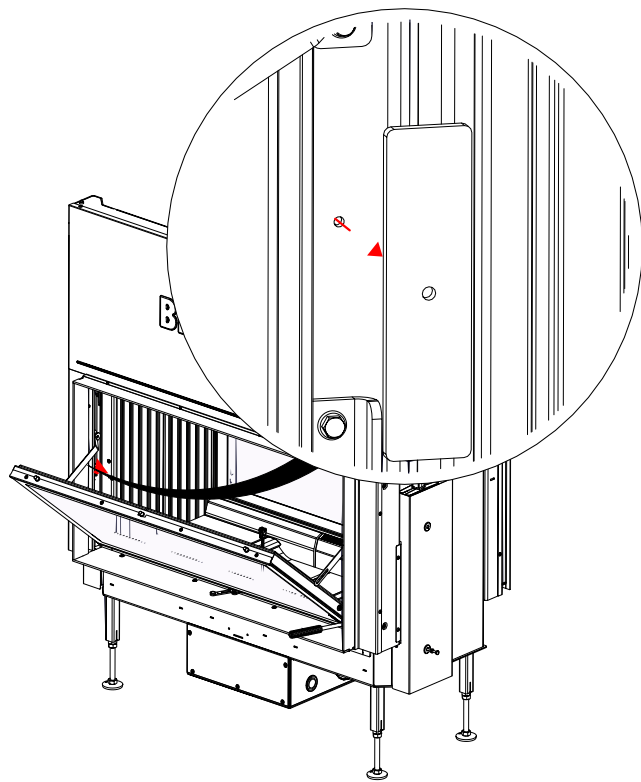

11.2 RETROFITTING EAS/EOS

Retrofitting an EAS or EOS is possible for BKH appliances in the 5.0 series. If retrofitting is desired, this must be specified when ordering. A few preparatory measures must be taken for retrofitting EAS/EOS, which are listed below.

Preparatory measures	Remark
Pull-in cable for thermal sensor	Pre-assembled at the factory
Possible opening for thermal sensor installation and EAS installation from the front	Advantageous, but not absolutely necessary
Empty conduits for EAS. power supply or EOS control unit	
Empty conduits between flush-mounted box for EAS (with and without display) or EOS control unit and appliance	
Empty conduits between the flush-mounted boxes control unit and display	for EOS
Control option	Provide relay A4

12 DISPOSAL

Old equipment contains valuable materials that must be recycled. Observe the applicable national legal regulations for disposal.



Danger of electrocution.

Electrical connections of the furnace system are under mains voltage. This can lead to electric shock.

Switch off the power supply

Secure power supply against restart.

Old metal parts can be disposed of as metal recycling.

Electrical and electronic components must be disposed of as electronic waste. Fireclay linings can be disposed of as rubble.

Fireclay linings can be disposed of as rubble.

Dispose of insulating and insulating materials of the heating or fireplace insert in a closed container on a suitable waste disposal site.

Do not put the glass ceramic discs in the waste glass collection container! The glass panes can be disposed of as normal household waste.

Recycling of catalytic converters containing precious metals

Oxidative catalytic converters, as installed in modern wood stoves, are very effective at reducing emissions of carbon monoxide and hydrocarbons. This is possible, because precious metals like platinum, palladium and rhodium are used on the surface of catalytic converters. These precious metals are distributed very evenly in very small amounts on the surface of catalytic converters. Over the years, the abrasive effect of particles streaming through the catalytic converter will cause the partial diminishing of the coating containing precious metals. Continuous overheating of catalytic converters ($T > 700\text{ °C}$) will damage the coating. In certain cases, the catalytic converter should be replaced and a new converter must be installed to ensure the catalytic effect.

Used catalytic converters are suitable for re-use. Even if they are broken or damaged, they are suitable for recycling.

Contained precious metals can be recovered by thermal or chemical separation techniques to almost 90%, and then used again in the manufacturing process.

Please bring the used catalytic converter to a recycling center.

Thank you very much for your efforts in supporting the protection of environment and sustainable use of resources.

Dimension sheets - BKH flat 50-82 green lifting door

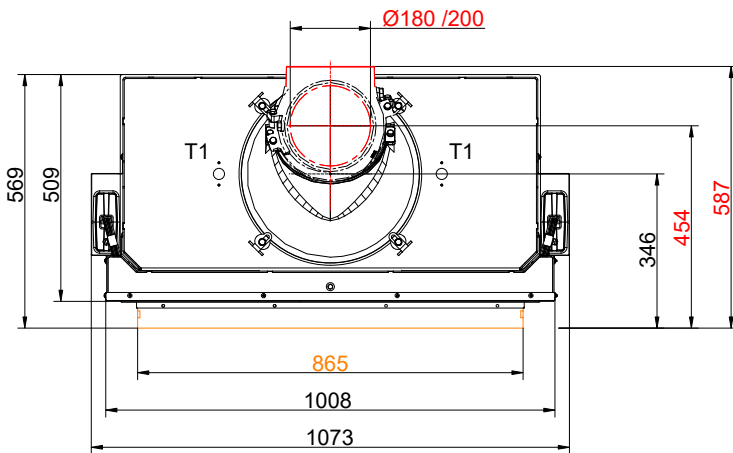
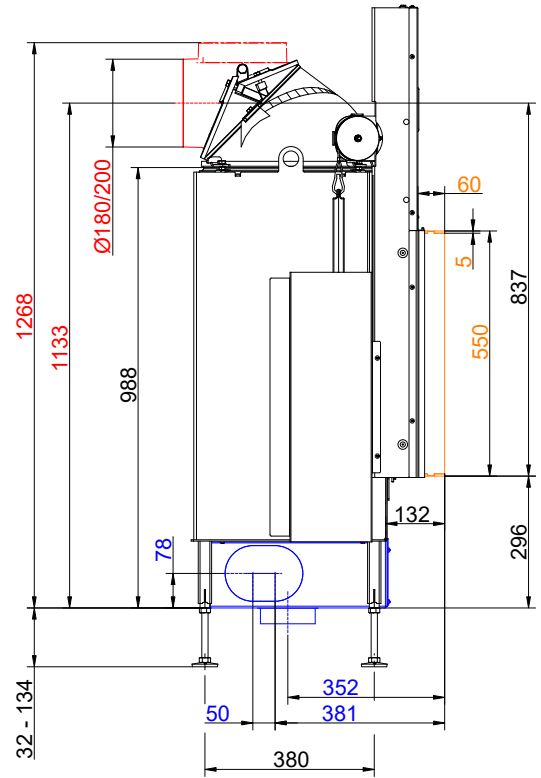
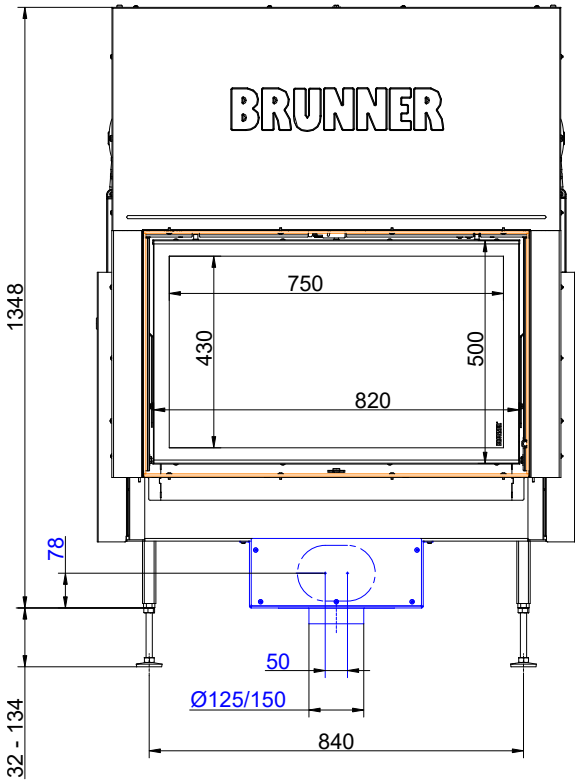

... with mounting frame and Cast iron dome

Dimension sheets - BKH flat 50-82 green lifting door

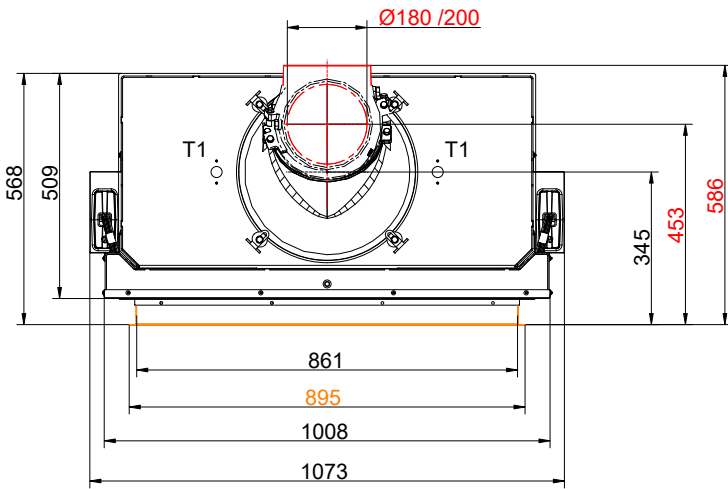
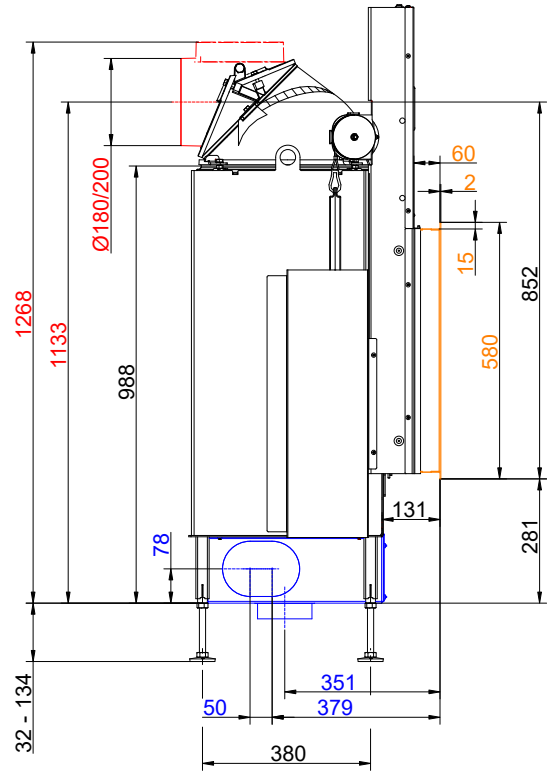
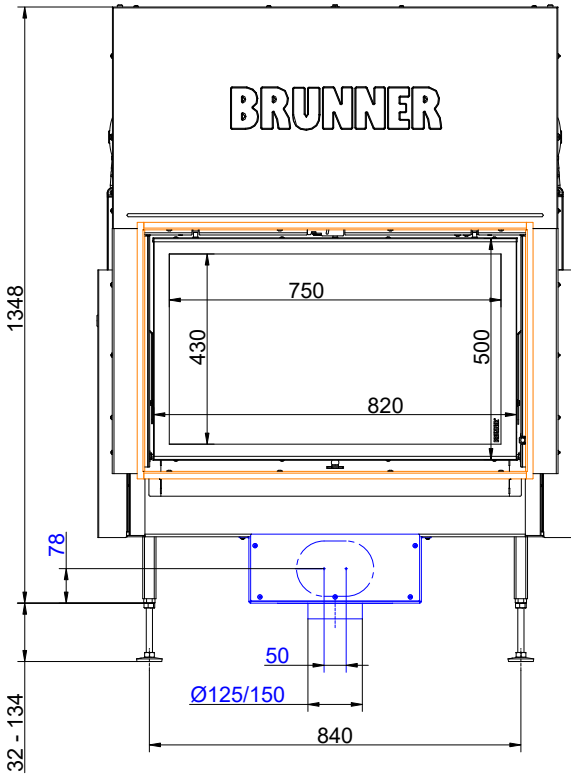

... door frame and cast iron dome

Dimension sheets - BKH flat 50-82 green lifting door

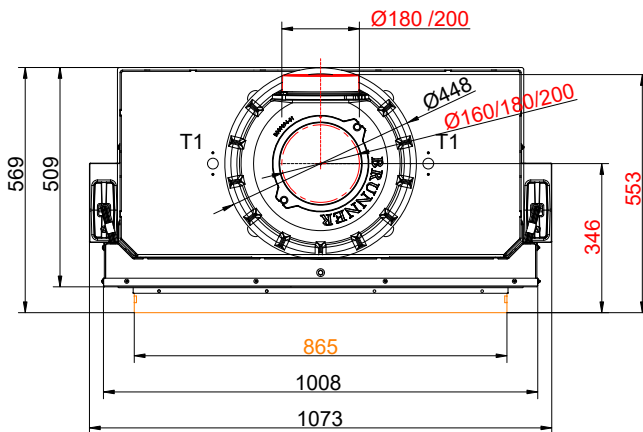
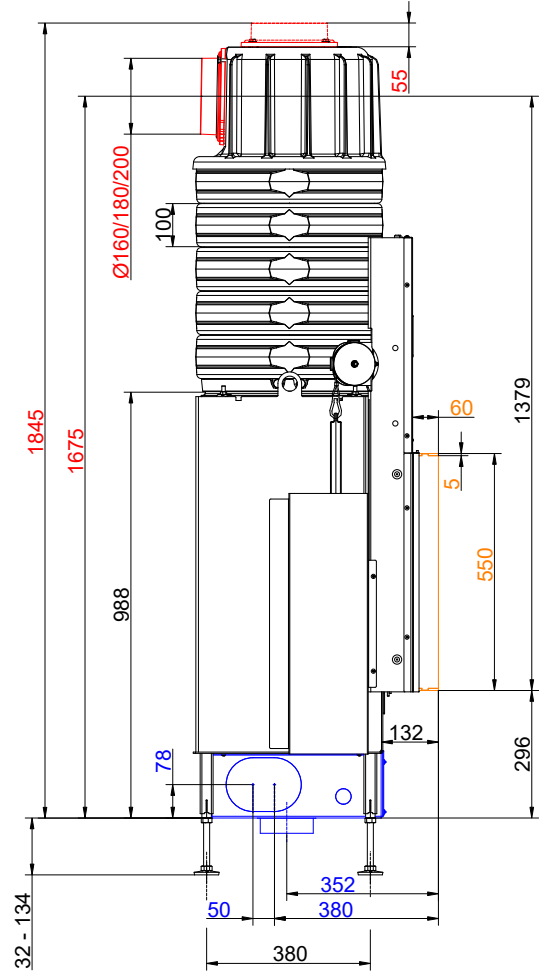
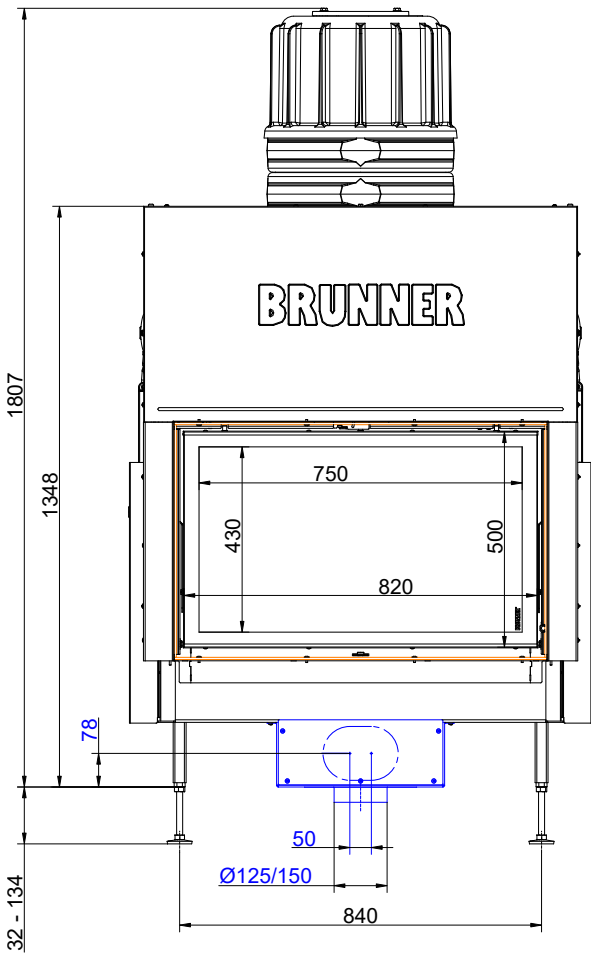

... mounting frame and MAS

Dimension sheets - BKH flat 50-82 green lifting door

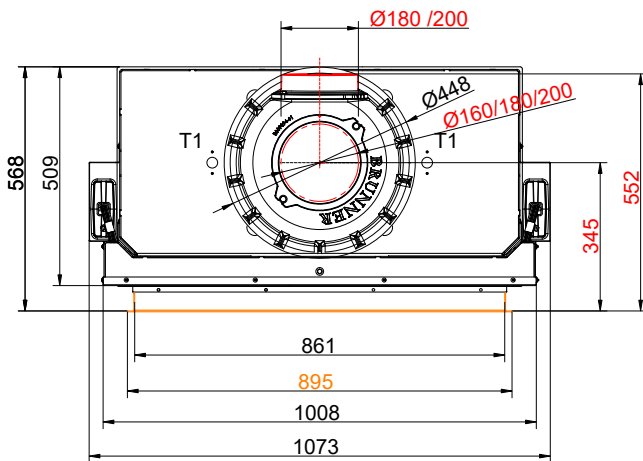
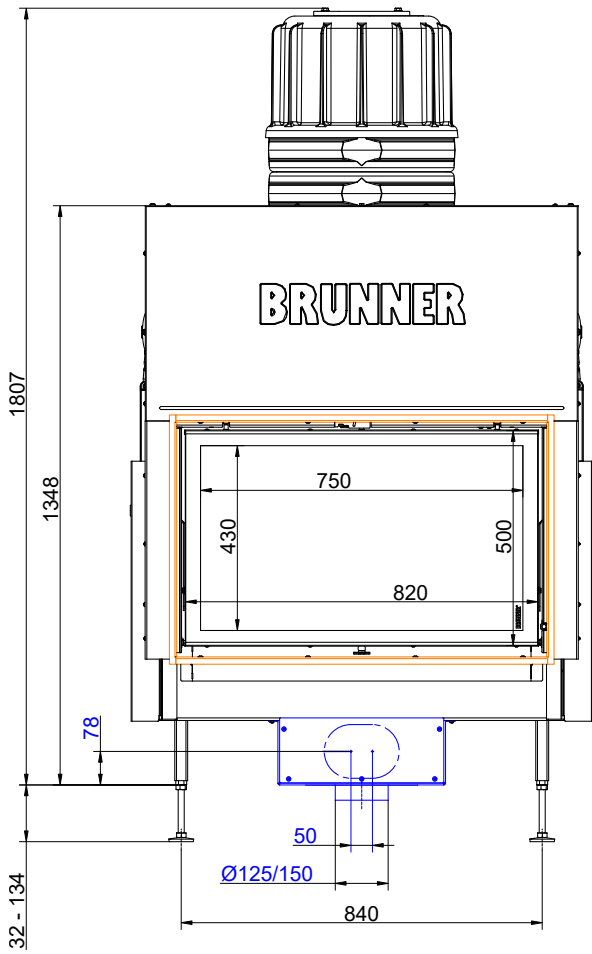

... door frame and MAS

Dimension sheets - BKH flat 50-82 green lifting door

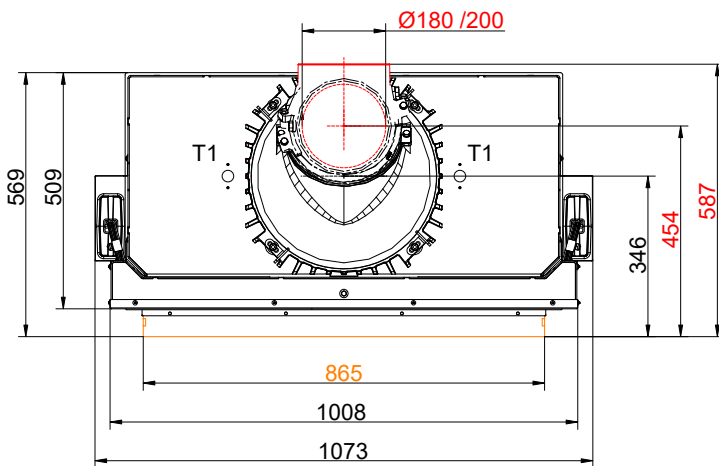
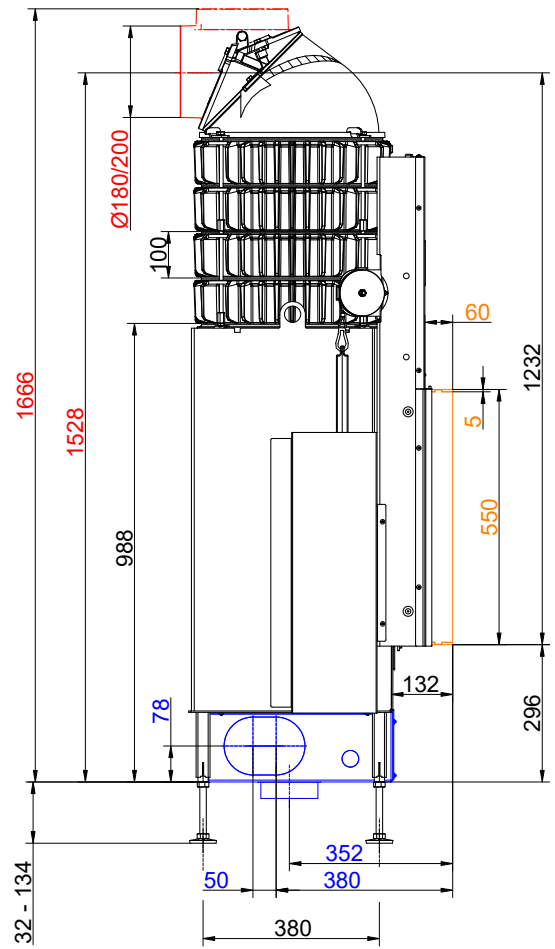
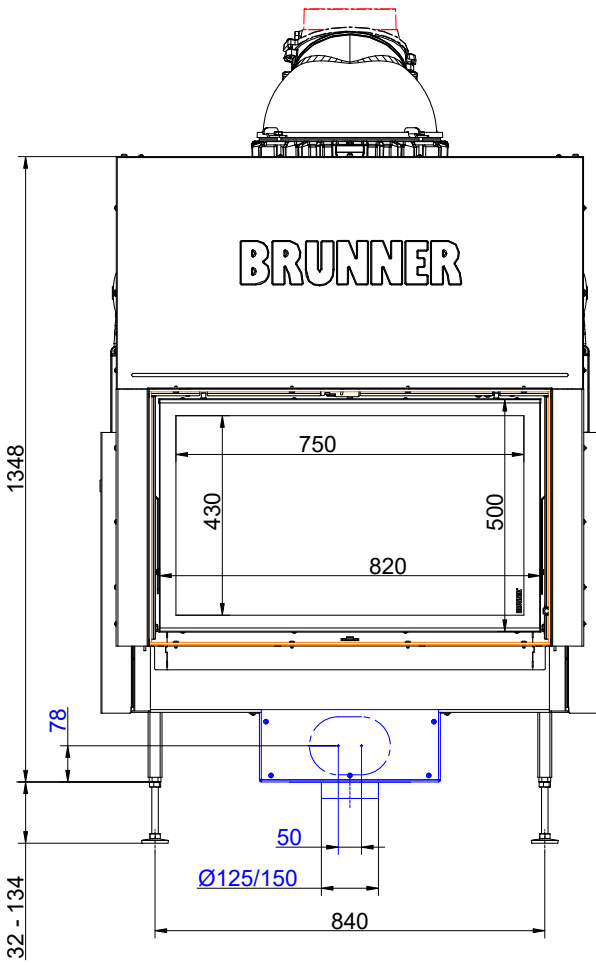

... Mounting frame and cast iron heat exchanger rings + dome

Dimension sheets - BKH flat 50-82 green lifting door

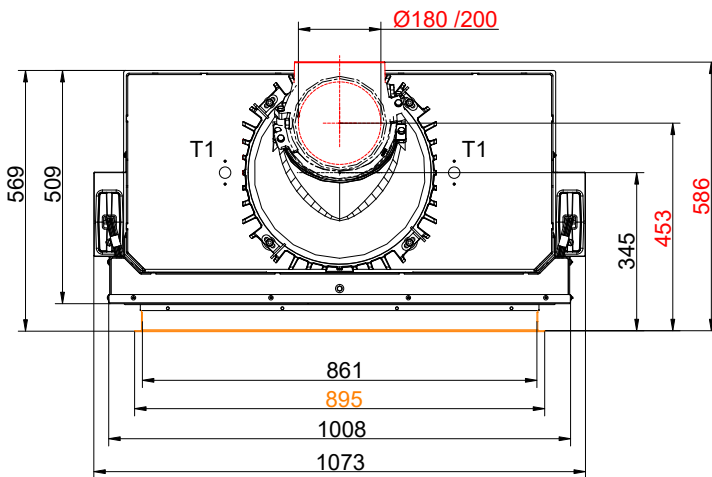
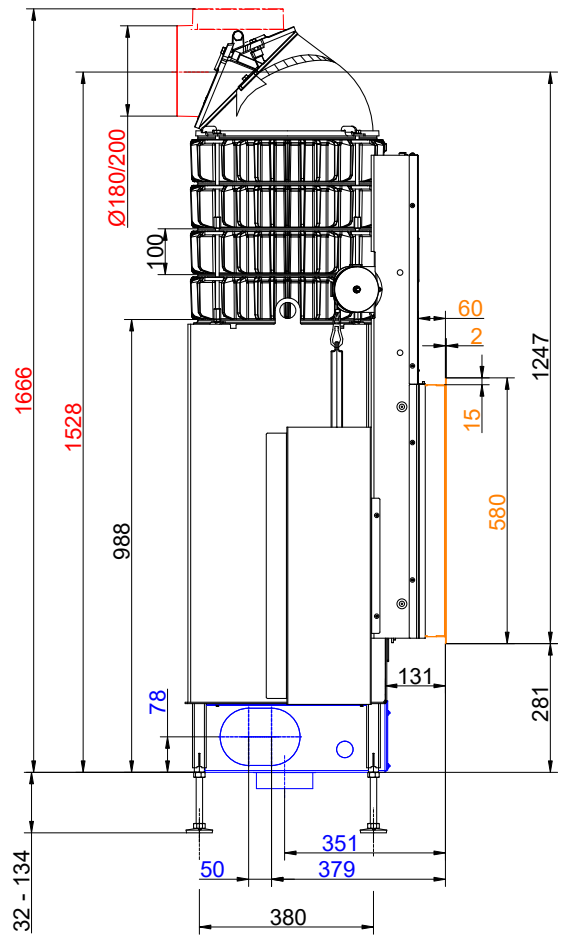
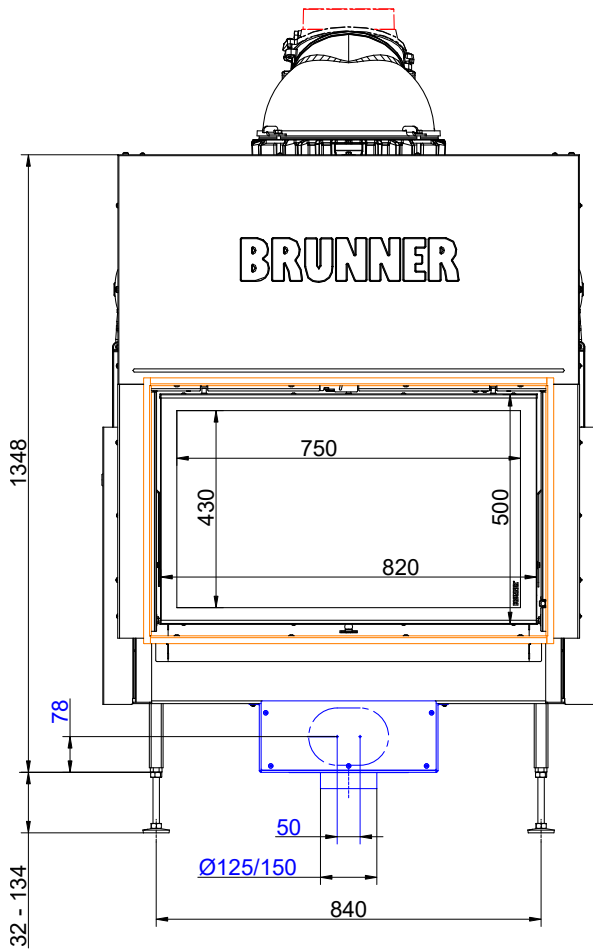

... Door frame and cast iron heat exchanger rings + dome

We suggest for CAD planning Palette CAD. Permanent updated drawings: www.brunner.de
 Frames/ flue gas outlet connection/ combustion air supply connection/ front variants/ support bearing are marked in color.

Planning and installation - BKH flat 50-82 green lifting door

Tested according to		EN 13229 W	EN 13229 WA
Values measured at		Rated power ¹⁾	Storage operation ²⁾
Data for functional demonstration			
Rated heat power	kW	10	-
Fire wood volume	kg/h	3.3	4.5
Combustion performance	kW	12.0	22
Flue gas mass flow	g/s	12.0	19
Flue gas temperature after:			
Cast iron dome	°C	250	350
4 x cast iron heat exchanger rings + dome	°C	210	260
5 x accumulation rings incl. MAS casted cover ³⁾	°C	-	260
2,0 m ceramic accumulator ⁴⁾	°C	-	180
1,4 m accumulation stones (MSS) ⁴⁾	°C	-	180
Necessary supply pressure	Pa	12	12
Fuel amount	kg	2.5	5.0
Combustion air consumption	m ³ /h	32	48
Combustion air connection Ø	mm	125	125
Heat distribution			
Insert / reheating surface	%	30 / 30	30 / 30
glass ceramic / glass ceramic coated (GKB)	%	40 / 30	40 / 30
Cross-section of gratings ⁵⁾			
exhaust warm air	cm ²	800	800
Recirculation air	cm ²	800	800
Minimal oven surface for closed construction type			
Heat dissipating surface	m ²	5.4	5.4
Minimal distances of the fireplace			
Heat protection panel for cladding, insulation layer	cm	-	-
to cladding, insulation layer	cm	5	5
to the floor (non-combustible)	cm	3	3
Minimum insulation thicknesses of substitute insulation material / reference insulation material + facing wall ⁶⁾			
with heat protection panel for mounting wall (non-combustible) ⁷⁾	cm	6 / 8	6 / 8
with heat protection panel for mounting wall (combustible) ⁷⁾	cm	12 / 13 + 10	12 / 13 + 10
to mounting wall (non-combustible)	cm	8 / 10	8 / 10
to mounting wall (combustible)	cm	18 / 20 + 10	18 / 20 + 10
to the ceiling (non-combustible)	cm	8 / 10	8 / 10
to the ceiling (combustible)	cm	22 / 25 + 10	22 / 25 + 10
to the floor (non-combustible)	cm	0 / 0	0 / 0
Minimum distances in front of the combustion chamber, glass ceramic / glass ceramic coated (GKB)			
for combustible parts	cm	≥ 120 / ≥ 80	≥ 120 / ≥ 80
Weight			
Fireplace insert + combustion chamber inner lining chamotte/cast iron	kg	185 + 96 / 115	
Meets requirement/limit values for:			
EU / Germany	Ecodesign / 1. BImSchV (Stufe 2)		

- 1) Indications to "Rated power" determined with 4 heat exchanger rings made of cast iron and Ø200 dome.
- 2) Indications to "Storage operation" for the manual execution of the reheating surface (guide values).
- 3) Damper flap recommended
- 4) Standard value or calculated functional proof required.
- 5) Air cross-sections if the specified nominal heat output is desired as the heat output.
- 6) Fire safety: values determined with air cross-sections evaluated by safety testing; stove cladding is heat emitting. Insulation material data with calcium silicate (Promasil 950KS)/10 cm wall lining + reference insulation material (mineral wool according to AGI Q 132).The specifications for walls/ceilings that do not require protection and are non-combustible correspond to the specifications of TROL (Germany).

Planning and installation - BKH flat 50-82 green lifting door

- 7) Heat protection panels (accessories) only available for selected fireplace inserts. For assembly and design of the heat protection panel see assembly instructions. Distance between mounted heat protection panel and fireplace insert: rear wall 2 cm, side wall 3 cm.

Product data sheet according to (EU) 2015/1186:

Supplier's name or trademark	Ulrich Brunner GmbH
Model identifier:	BKH 5.0 Flach 50-82 green ST
Energy efficiency class:	A+
Direct heat output:	10,0 kW
Indirect heat output:	N.A. kW
Energy efficiency index:	112
Fuel energy efficiency (at nominal heat output):	83,0 %
Fuel energy efficiency (at minimum load):	N.A. %
Special precautions: see supplied product documentation	

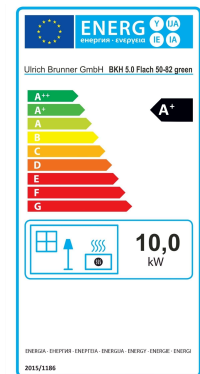
**Ulrich Brunner GmbH**

Zellhuber Ring 17-18

D-84307 Eggenfelden

Phone: +49 (0) 8721/771-800

E-Mail: info@brunner.de**Copyright**

All information, drawings and technical descriptions contained in this documentation are our property and may not be reproduced without prior written permission.

® **BRUNNER** is a registered trademark.

Subject to technical changes and errors.

© by Ulrich Brunner GmbH

Doku-Nr.: 202965